

An Investigation to Improve Quality Evaluations of Primers and
Propellant for 20mm Munitions

L. J. Bement
C. Holmes
J. McGrory
M. L. Schimmel

Presented at the
Munitions Technology Symposium IV

February 10-12, 1997

Reno, Nevada

SUMMARY

To reduce the frequency of electrically initiated, 20mm munition hangfires (delayed ignitions), a joint Army/NASA investigation was conducted to recommend quality evaluation improvements for acceptance of both primers and gun propellant. This effort focused only on evaluating ignition and combustion performance as potential causes of hangfires: poor electrical initiation of the primer, low output performance of the primer, low ignition sensitivity of the gun propellant, and the effects of cold temperature. The goal was to determine the "best" of the Army and NASA test methods to assess the functional performance of primers and gun propellants. The approach was to evaluate the performance of both high-quality and deliberately defective primers to challenge the sensitivity of test methods. In addition, the ignition sensitivity of different manufacturing batches of gun propellants was evaluated. The results of the investigation revealed that improvements can be made in functional evaluations that can assist in identifying and reducing ignition and performance variations. The "best" functional evaluation of primers and propellant is achieved through a combination of both Army and NASA test methods. Incorporating the recommendations offered in this report may provide for considerable savings in reducing the number of cartridge firings, while significantly lowering the rejection rate of primer, propellant and cartridge lots. The most probable causes for ignition and combustion-related hangfires were the lack of calcium silicide in the primer mix, a low output performance of primers, and finally, poor ignition sensitivity of gun propellant. Cold temperatures further reduce propellant ignition sensitivity, as well as reducing burn rate and chamber pressures.

INTRODUCTION

The U.S. Army's quality assurance functional test methods for the manufacture of electrically initiated 20mm munitions have not prevented hangfires. Hangfires, delayed cartridge initiations, have occurred infrequently in rapid-fire weapons at a rate averaging one in several hundred thousand firings. Misfires can be accommodated (the round is simply ejected), but hangfires have serious consequences to aircraft and other systems where such weapons are installed. Problems range from jamming the gun, effectively disarming the weapon system, to structural damage and hazards to personnel. A helicopter gunship was forced to crash land following such an incident.

The electrically fired 20mm cartridge (figure 1) is used in weapons, such as the electric or hydraulic-driven M61, six-barrel Gatling gun. At the maximum firing rate of 7,200 shots/minute, the breech is closed less than 8.4 milliseconds for each cartridge firing. A delayed ignition allows the round to ignite when the breech is not seated into the barrel, during withdrawal of the round, or in the worst case, after the round is completely withdrawn from the gun's barrel. The brass cartridge case is unable to contain the combustion gases and bursts, producing damaging pressure waves and high-velocity fragments.

In response to an August 30, 1991, request for support from the U.S. Army Armament Research, Development and Engineering Center to the NASA Langley Research Center, a joint agreement was initiated. The intent of the agreement was to determine the potential for applying the Ignitability Test Method, developed at NASA Langley, to expand Army capabilities in the evaluation of 20mm ignition interfaces.

A large number of mechanical and electrical failure modes exist in this complex Gatling gun. The effort described in this paper focused only on failure modes associated with the electrical initiation of the primer, the output of the primer that initiates gun propellant, and the ignition of the gun propellant. Four possible causes of hangfires were considered:

1. Delays in the electric initiation of the primer itself.
2. Poor output performance of the primer, resulting in a poor input of heat, gas, light and burning particles to ignite the gun propellant.
3. Insensitive gun propellant that is difficult to ignite.
4. Cold primer and propellant could inhibit both electrical initiation of the primer, as well as the initiation of the propellant.

As described in detail under the ITEMS TESTED section in this report, the 20mm primer (reference 1) and gun propellant (reference 2) have a number of weaknesses that could lead to ignition and combustion-related hangfires. In brief for the primer: 1) the primer load could be undersized, which would produce a low output performance, and 2) the lack of one ingredient (calcium silicide) in the primer composition can delay electrical initiation of the primer. For the gun propellant: 1) the burn rate and energy delivery on occasion have shown considerable variability, and 2) it may be difficult to ignite.

Functional test methods to evaluate the functional performance of primers and propellants have been developed by the U.S. Army and the NASA. Conventional tests used by the Army measure the primer electrical initiation sensitivity and function time by individual test firings in fixtures (primers installed in cartridge cases). Also, fully assembled cartridges are fired in guns to measure performance of both primers and propellant in the final application. The unique Ignitability Test Method, developed by NASA Langley Research Center, evaluates performance by firing primers into gun propellant and measuring the ignition and combustion response of the propellant to the initiation stimuli. This is the only published test method that can individually quantify the output ignition performance of primers, as well as the ignition sensitivity of propellants. References 3, 4, 5 and 6 document an unprecedented capability to measure and compare performance of a wide variety of primer types, propellant types, and functional conditions.

The goal of this investigation was to recommend improvements in quality assurance functional test methods that could minimize the inadvertent acceptance of primer and propellant weaknesses which could lead to ignition and combustion-related hangfires.

To meet this goal, the objectives were to:

1. Assess the performance of existing Army and NASA functional test methods and recommend the "best" test approach in terms of data collected and costs.

2. Determine and prioritize possible causes of ignition and combustion-related hangfires.

The approach for this investigation was to:

1. Compile and compare primer and propellant functional performance data produced through the use of Army and NASA test methods.
2. Challenge the sensitivity of these test methods by compiling the ignition and combustion performance of high-quality (Control) primers for comparison to that of deliberately flawed primers. The flaws in these primers were designed to reduce the output of primers (Half Load) and to delay primer ignition (No Calcium Silicide).
3. Determine the ignition and combustion-related performance effects of functioning primers conditioned at - 65°F.
4. Evaluate two manufacturing lots of gun propellant with the Ignitability Test Method to assess ignition performance variations.

ITEMS TESTED

This section provides a generic description of 20mm primers and gun propellant, as well as the specific items tested.

M52A3B1 Primer Generic Description

The electrically initiated M52A3B1 primer is shown in cross section in figure 2 and is described in reference 1. The external brass cup houses an electrically isolated brass button, the primer mix and a support cup. The composition of the mix, as shown in table I, has three major ingredients: 44.25% barium nitrate, 40% lead styphnate and 13% calcium silicide. Electrical initiation of the primer is accomplished by an electrical discharge from the button, through the mix, to the external cup. The typical electrical firing circuit used is a 160-volt-charged, 2-microfarad (uf) capacitor. The actual mechanism of electrically igniting the mix has not been determined. Acceptable performance is achieved with a very large electrical resistance tolerance: a minimum of 1,000 to a maximum of 1,200,000 ohms. Early testing in this program revealed that calcium silicide was critical in providing an electrical conduction path through the mix to achieve rapid ignition.

Primers are manufactured in "lots" that average 500,000 units. A lot is a carefully controlled manufacturing process in which all ingredients are from single, traceable, high-quality sources. Mixing and loading are conducted under tightly specified procedures. The ingredients are mixed, water-wet, in 12-pound batches. Each 12-pounds of mix yields approximately 26,000 primers. Primers, which are assembled from one or more primer mix batches in a given day, are segregated and identified as a sub-lot. Therefore, to obtain the average 500,000-unit lot size, several days of mixing and loading are required. Sample primers are collected at random during each day's production (sub-lot)

for subsequent test firings in the three different Army test methods; these samples are not segregated for subsequent traceability to the original primer mix batch. Before the primer samples are assembled into cartridge cases for test firing, all the sub-lot samples are combined into a single mixed group. The primed cartridge cases submitted for primer acceptance testing are not identifiable as to sub-lot or primer mix batch numbers. Chemical analyses of the mixes are conducted on a case-by-case basis if requested; there is no current requirement to analyze each batch of mix, or sub-lot or lot of primers produced. The quantity (load) of primer mix within the primer is monitored by measuring the height of the load in the cup of each primer. The weight of the primer mix in the assembly (allowable range is 145.9 to 194.5, nominally 185 milligrams) is checked approximately every half hour on a small-sample, random basis.

Specific Primers Tested

Three lots of primers were manufactured for the experimental program: a Control, Half Load and No Calcium Silicide. To limit the number of variables, all primers used the same source of ingredients, except for deleting the calcium silicide in the third group.

Control - The Control 20mm munition electric primer, (figure 2, reference 1), contained a nominal 185-milligram load (charge weight) of primer mix. This lot was manufactured especially for this program.

Half Load - The same primer mix used for manufacturing the Control primer was also used in the Half Load primers. The final charge weight was sized to 100 milligrams. The primer loading procedures were modified from those used by the Control to assure that the load weight and density were uniform. The Half Load primer's loading density was the same as that of the Control primer.

No Calcium Silicide - The same pyrotechnic ingredients that were used in the Control primer, except for deleting calcium silicide, were loaded into the No Calcium Silicide primer. These primers were assembled with a nominal 185-mg load at the same density.

Standard - The primer "standard," that was selected and used for comparing the ignition sensitivity of manufacturing lots of gun propellant with the Ignitability Test Method, was LC90H721-225. This was a routine production lot that was manufactured outside of this study.

Gun Propellant Description

The gun propellant, reference 2, table II, is a double-base (primarily nitroglycerine/nitrocellulose) composition that has been known for lot-to-lot and even within-lot

performance variations. A "lot" is a 40,000 to 60,000-pound batch of propellant that is manufactured under controlled procedures and conditions, using only single-source ingredients that are manufactured under equally controlled procedures and conditions. To accommodate performance variations, sufficient free volume has been designed into the cartridge to "size" the propellant for each lot of cartridges. That is, the amount of propellant loaded into each cartridge is based on firing sample cartridges in a test gun barrel. The cartridge load size is dictated by the chamber pressure in the test barrel, the time from applying the electrical firing signal to the projectile leaving the gun barrel (action time), and the measured velocity achieved by the projectile at 78 feet from the end of the barrel. For example, if the projectile velocity is too high, the amount of propellant is reduced, and if the velocity is too low the amount of propellant is increased. However, if the chamber pressure is too high, indicating that the energy delivery of the propellant is inadequate, the propellant load cannot be increased and the lot has to be rejected or reworked. Unfortunately, the propellant performance in cartridge firings conducted at the munitions plant often do not match the supposedly identical lot acceptance performance achieved by the propellant manufacturer. Throughout the final assembly of cartridges, propellant performance is monitored through cartridge firings; the amount of propellant may be resized several times, or individual shipping drums of propellant may be rejected, in any particular propellant lot. In all cartridge firing tests, the output performance of the primers used is assumed to be constant; lot controls are not applied to primers during final assembly of cartridges. Thus, several lots of primers may be used in each lot of cartridges.

Specific Propellant Tested

Three different lots of WC872 gun propellant were used in this program. All lots were manufactured under conventional manufacturing and performance requirements.

1. Lot number 49701 was selected and used as the "standard" by the Army in all cartridge firings.
2. Lot number 49438 was selected and used as the "standard" in tests with the Ignitability Test Method.
3. Lot number 49450 was evaluated using the Ignitability Test Method for comparison to the performance achieved by lot number 49438.

EXPERIMENTAL PROCEDURE AND TEST METHODS

Parallel functional evaluations were conducted on the three primers (Control, Half Load and No Calcium Silicide), using the conventional Army test methods and the Ignitability Test Method. The data was collected and analyzed to recommend the most informative and cost-effective test methods. The following describes the test apparatus and operational procedures of the Army's conventional test methods and the Ignitability Test Method, which were used to evaluate the performance of both primer and propellant lots.

Army Functional Test Methods

Performance requirements for the 20 mm primer consist of three tests: primer sensitivity, primer time and cartridge firings. These tests are detailed in the primer specification, reference 1.

Primer Sensitivity - This test evaluates a sample of primers from the manufacturing lot to determine the threshold, or an "average critical voltage" level and standard deviation to achieve primer initiation. All tests are conducted at laboratory ambient conditions. The primers are pressed into empty cartridge cases that allow the primer output to vent. This assembly is installed into a test fixture and voltage applications are made by discharging a 2 uf capacitor, preset to the desired test voltage level. The lot sample is divided into subsamples of 50 units. Testing of the first subsample begins at 40 volts. Each unit is pulsed with the electrical discharge; fires and no-fires are recorded in the columns indicated in table III. The next subsample is tested at a 10-volt higher increment, 50 volts. The process is repeated until a voltage level is reached, where all of the units in a subsample successfully fire. The next subsample series is tested at 30 volts; the voltage level is decreased in 10-volt increments until a level is reached where all units in a subsample series do not fire. The fire/no-fire data are summed and an average critical voltage level (V), and standard deviation (sd) are then calculated, as shown in table III.

This primer sensitivity procedure was modified for the effort described in this report, as follows:

1. A subsample of 10 was used, rather than the prescribed 50.
2. A sample of 160 primers was used, testing at incremental voltage levels from 10 to 160 volts. That is, a group of 10 primers were fired at 10 volts, a second group of 10 at 20 volts, etc., to the 160-volt level.

An example of calculations to determine the average critical voltage and standard deviation is provided in the RESULTS section.

The performance criteria are: If the average critical voltage (V) plus three standard deviations exceeds 160 volts, the lot shall be rejected. If in either the first test or retest, a primer fails to fire at 160 volts, the lot shall be rejected.

Primer Time - This test evaluates the function time of the primer from application of voltage to the detection of primer output of hot gases and particles. All tests are conducted at laboratory ambient conditions. The primers are installed in empty cartridge cases. The case is placed (base up) into a cavity, which contains an ionization probe concentric to the axis of the case. The probe projects inside the cartridge case to a close proximity to the output of the primer. When the primer is fired, the primer output, which contains ionized gasses, electrically shorts a circuit on the end of the probe, stopping a timer that is set to measure the elapsed time from application of the firing voltage to the output of the primer. Typical elapsed times are approximately 70 microseconds. Groups

of 20 units each are test-fired at laboratory ambient at 160 volts, discharged from a 2 uf capacitor firing circuit.

The performance criteria are: If the sample average primer time plus four standard deviations exceeds 0.300 millisecond or if an individual primer time of the test sample exceeds 0.300 millisecond, the lot shall be rejected.

Cartridge Firings for Pressure/Action time/Velocity -This test evaluates the performance of both cartridges and gun propellants. Assembled cartridges, using the test lots of primers or gun propellant, are conditioned in a cold chamber for four hours at -65°F. The cartridge is manually transferred from the chamber and inserted into a test gun barrel for firing. The electrical firing circuit for this test is a 4 uf capacitor, charged at 206 volts. Measured are the barrel's chamber pressure, the action time, and the projectile's velocity. Chamber pressure is determined by measuring the crush deflection of calibrated copper discs installed in the chamber. Electronic timing circuits measure the action time and the projectile velocity. Action time is the time interval from the application of the electrical firing pulse to the cartridge's projectile clearing the muzzle of the barrel. Projectile velocity is determined by measuring the time interval over which the projectile traverses a known distance; velocity is calculated by dividing this distance by the time interval.

The performance criteria are: If the average primer action time plus four standard deviations exceeds 3.5 milliseconds or an individual primer action time of the test sample exceeds 3.5 milliseconds, the cartridge lot shall be rejected.

Ignitability Test Method

The purpose of this test method, shown in figure 3 and described in references 3, 4, 5 and 6, is to measure the response of flammable materials to ignition inputs from primers (heat, light, gas and burning particles). It can be used to test the output performance of primers, using a propellant "standard," or to test the input ignition sensitivity of propellant, using a primer "standard." That is, to measure the output performance of different lots of primers, the primers would be fired into the propellant standard. Conversely, to measure the ignition sensitivity of different lots of propellants, a primer standard would be fired into the test propellants. These standards would be selected from lots with a demonstrated history of uniform performance. They would be stored under ideal conditions and used only for this type of testing.

The principle for measuring and comparing the performance of primers is that the response of a standard propellant to a primer input is based on the amount and rate of that input. That is, the rate at which the propellant ignites and burns is directly related to the primer ignition input; the "hotter" the primer, the more rapidly the propellant ignites and burns. The primer is fired into a 0.888-inch diameter hemispherical cavity, containing 2500 mg of gun propellant in the ignition material holder. The gas generated by the

combustion vents through twelve, 0.030-inch diameter holes in the bottom of the holder to pressurize the lower volume. This pressure is measured by redundant transducers. The vent holes were sized at 0.030 inch to retain the 0.040-inch diameter gun propellant granules in the cavity. These holes are temporarily sealed by the propellant granules to retain the output gases from the primer in the ignition material holder. Thus, the input from the primer is confined to the ignition material in the holder. This temporary plugging of the vent holes is effective, since the extremely dynamic pressure produced by the primer is not detected by the pressure transducers. The gases created by the burning of the propellant produce a "signature" pressure response to the input of the primer.

The top and bottom threaded plugs allow for quick disassembly and thorough cleaning to assure that the same initial conditions are established for each test.

The definitions of the data collected are shown in figure 4: primer time, ignition time, pressure at 1 ms, time to peak pressure, peak pressure, and ignitability. Since this method is new to this application, performance criteria will have to be established.

Primer Time - Primer time is measured from the application of the electrical firing signal to ignition of the primer charge; an accelerometer, mounted on the primer holder, detects the mechanical shock produced by the explosion of the lead styphnate in the primer on initiation. Primer time data were collected only during the propellant evaluations, since this method was established late in the program.

Ignition Time - Ignition time is measured from the application of the electrical firing signal to the first indication of pressure; since it is difficult to detect the first pressure rise, a value of 800 psi (a small value, relative to the peak pressure normally observed (20,000 psi) was selected as a reference.

Pressure at 1 ms - The pressure level achieved at 1 millisecond was based on a past measurement, described in reference 3, which indicated that virtually all of the energy produced by primers for small-arms ammunitions was emitted in 1 millisecond.

Time to Peak Pressure - The time to peak pressure was also measured from the 800 psi reference.

Peak Pressure - The peak pressure achieved in the volume is affected by ignition; a poor ignition will cause a slower pressure rise and a lower peak pressure, due to a longer period of time to allow heat loss of the hot combustion gasses into the hardware. When propellants are being evaluated, burn rate also affects peak pressure. A slower burn rate will allow the same heat loss.

Ignitability - Ignitability is obtained by ratioing the pressure achieved at one millisecond to the peak pressure. This is a relative figure of merit. The larger the number, the "hotter" the primer.

Since no test requirements and functional criteria had been established for the Ignitability Test Method, functional tests were conducted on the three primers both at laboratory ambient conditions and at -65°F. The primer was pressed flush to the top of the cavity in the primer holder, and the hardware was assembled. The -65°F tests were conducted by placing the entire assembly in a chamber, which contained dry ice. The chamber allowed access only from the top. The high-density carbon dioxide prevented the entry of air and subsequent water condensation. The primer was fired 15 minutes after the assembly achieved the desired temperature. Each primer was weighed before and after firing to assure that the load weights were uniform.

To determine variations in batch-to-batch performance of WC872 gun propellants, the Ignitability Test Method was used to evaluate two different manufacturing lots, #49438 and #49450.

RESULTS

For the Army tests, the results were:

Primer Sensitivity - The primer sensitivity test results are shown in table IVA. The Control group had the lowest average critical voltage at which ignition was achieved. The Half-Load group had a significantly higher average critical voltage level. However, the No Calcium Silicide group was insensitive enough to just fail the performance criterion: the average critical voltage plus 3 standard deviations shall be less than 160 volts. An example for calculating critical voltage and its standard deviation is shown in table IVB.

Primer Time - The primer time test results are shown in table V. The Control group again was the most responsive, followed by the Half Load and the slow-performing No Calcium Silicide. All primer groups met the performance criterion: the average primer time, plus 4 standard deviations, shall not exceed 300 microseconds.

Cartridge Firings for Pressure/Action Time/Velocity - The results of the pressure/action time/velocity tests are detailed in tables VI, VII and VIII, and are summarized in table IX. The Half Load primers clearly exceeded the performance criterion: the average action time plus 4 standard deviations shall not exceed 3.5 milliseconds. However, the misfire in the No Calcium Silicide group was the only cause for rejection. Once all three of the primer types fired, the peak pressures achieved and the projectile velocities were comparable for all three groups.

For the Ignitability Test Method, the results were:

Primer Evaluations - The Ignitability Test Method results for the three primers are detailed in tables X, XI, and XII, and are summarized in table XIII. The Half Load

primers had the poorest ignitability of any of the primers tested. This poor ignitability is reflected in longer times to peak pressure and lower peak pressures. This was further accentuated at -65°F, as compared to the performance at laboratory ambient conditions. Although the ignition time (time from application of the firing signal to first indication of pressure) of the Half Load primers (0.45 ms) was comparable to the other primer types at laboratory ambient conditions, a considerable increase (0.82 ms) was observed at -65°F. The ignition time performance of the other test primers remained unchanged at cold temperatures.

Propellant Evaluations - The results of the evaluation of two batches of propellant, shown in table XIV, exhibited considerable performance differences. Propellant Lot #49450 was much less sensitive to ignition than was Lot #49438 in all test parameters: (1) ignition time was 25% longer (0.54 versus 0.43 ms), (2) time to peak pressure was 17% longer (2.57 versus 2.20 ms), (3) peak pressure was 11% lower (18,080 versus 20,040 psi), and (4) ignitability was 30% lower (40.5 versus 57.8%).

CONCLUSIONS AND RECOMMENDATIONS

The goal of this joint Army/NASA investigation was met: To reduce the opportunity of 20mm munition hangfires, improvements were identified and recommended for 20mm munition quality assurance functional test methods to minimize the acceptance of primer and propellant ignition and combustion weaknesses. In addition, the most likely causes of these ignition and combustion-related weaknesses were listed in order of significance.

The results of parallel evaluations with Army and NASA functional test methods of high-quality and deliberately flawed primers and two different lots of gun propellant revealed that the recommended "best" approach is as follows:

1. Primer Sensitivity - The Army primer sensitivity test provides a straightforward, accurate, inexpensive approach to determining the threshold firing voltage. The following modifications should be considered:
 - a. This method should be used to evaluate each "batch" or sub-lot of primers. That is, each mix of composition, yielding about 26,000 primers, or sub-lot, a daily production, which could contain several batches, should be individually characterized to assure uniformity.
 - b. The acceptance criteria should be set to a much lower level; terribly flawed primers, containing no calcium silicide, very nearly were accepted by the current procedure.
2. Primer Time - Primer time acceptance criteria should be significantly reduced. The current criteria did not justify the rejection of terribly flawed primers. The primer time data collected in this investigation revealed significant increases in primer ignition delays in the Half Load and No Calcium Silicide primers. Further evaluations should be conducted with the NASA-developed Ignitability Test Method to determine if the Army

test method can be replaced; primer time data can be collected as additional performance parameters are being compiled.

3. Primer Output - The Ignitability Test Method, which can evaluate both sides of the primer-to-propellant interface, overcomes the most serious weakness of cartridge test firings in a gun: If a long action time is observed in a cartridge firing, the actual cause of ignition delay cannot be identified. This test method measures the ignition response of gun propellant to the output of primers to quantify the following parameters:

- a. Primer Time, the time from application of the firing signal to the primer output.
- b. Ignition Time, the time from application of the firing signal to first indication of pressure, or propellant ignition.
- c. Peak Pressure, the maximum pressure level achieved within the internal volume of the test apparatus.
- d. Time to Peak Pressure, the time from first indication of pressure to achieve peak pressure within the test apparatus.
- e. Ignitability, the ratio of the pressure achieved at 1 millisecond to the peak pressure.

The Ignitability Test Method can be used to compare the performance of primers and propellants to standards or acceptance criteria.

4. Cartridge Firings - Cartridge firings for primer and propellant lots remain an important performance demonstration. Cartridge firings for propellant evaluations should use a single lot of standard primers, rather than assuming that "all primers are alike." However, the number of firings can be reduced through an expanded use of the Ignitability Test Method; more frequent evaluations of both primers and propellant should lead to improvements in lot uniformities, thus reducing the need for daily cartridge firings to size propellant loads during cartridge assembly. Cartridge firings at the propellant manufacturing site may be eliminated, once confidence in propellant uniformity has been achieved with the Ignitability Test Method.

5. The Primer Sensitivity Test and Ignitability Test Method should be used "in process" during manufacture of both primers and propellant. Flaws in mixing or assembly could be recognized early, allowing corrections to be made and possibly avoid rejection of primer, propellant or cartridge lots. Particular emphasis should be placed on evaluating each "batch" or at least sub-lot of primers. The sampling and testing procedures currently in use could allow a defective sub-lot to cause rejection of the entire primer lot. Conversely, there is no assurance that a defective sub-lot is adequately sampled and tested to prevent its acceptance, incorporation into cartridges and delivery to the field.

6. The Ignitability Test Method proved to be very sensitive in detecting the following variables, that could not be isolated, prior to the introduction of this test approach:

- a. The lack of calcium silicide in the primer mix had no effect on the ignition of gun propellant.
- b. Reduced primer loads cause a significant reduction in output performance, which results in poorer ignition characteristics of gun propellant.

- c. Ignition sensitivity of different lots of gun propellants also changes considerably, along with the already recognized variations in burn rate and energy delivery.
7. The recognition of performance variations was further enhanced by firings conducted at cold temperatures (the standard procedure for Army cartridge firings). In tests with the Ignitability Test Method it was found that cold temperature induced considerable delays in the first indication of propellant ignition of underloaded primers, but had little effect on that produced by the Control or No Calcium Silicide primers. The Ignitability Test Method offers improved test repeatability over cartridge firings; the entire test apparatus was conditioned, which better controls temperature and condensation, as compared to cartridge firings in which only the cartridge is conditioned.
8. The cost of using a combination of modified versions of Army test methods and the Ignitability Test Method should yield a considerable cost savings through reducing the number of cartridge firings, while providing more definitive functional information.
9. As a final recommendation, the test logic suggested from this study should be extended to the evaluation of all the ingredients and variables in both primers and propellant. This study investigated the variation of only two primer parameters, eliminating one ingredient and reducing the load. The remaining ingredients could be varied over a real-world range of composition and primer loads. The process could be duplicated for gun propellant. The information gained would allow immediate interpretation of acceptance data and corrections could be made in the manufacturing cycle, should performance vary outside of desirable norms.

An analysis of the results of this investigation indicated that the potential causes for ignition and combustion-related hangfires in order of importance are:

1. Inadequate amounts of calcium silicide in the primer mix. The effect is that the electrical initiation of the primer itself is delayed. However, the output performance (capability of these primers to ignite propellant) was unaffected.
2. Poor output performance of the primer (heat, light, gas and burning particles). Low performance can be caused by a low primer load. The effect is slow ignition of the gun propellant.
3. Insensitive gun propellant that is difficult to ignite.
4. Cold temperatures. A temperature level of -65°F induced delays in all aspects of propellant ignition and combustion. Propellant ignition delays were doubled with half-loaded primers. Propellant burn rate was reduced, which led to longer times to peak pressures and lower chamber pressures.
5. A combination of all of the above. That is, if each of the four above items was at the low end of allowable ranges, the summation could yield excessive ignition delays.

REFERENCES

1. Military Specification MIL-P-1394F: Primer, Electric, M52A3B1
2. Military Specification MIL-P-3984J, Propellants for small Arms Ammunition and Drawing 9326796, Propellant, WC872.
3. Bement, Laurence J.; Schimmel, Morry L.: Ignitability Test Method. Presented at the 1988 SAFE Symposium, Las Vegas, NV, December 5-8, 1988.
4. Bement, Laurence J.; Schimmel, Morry L.: Ignitability Test Method - Part 2. Presented at the 1989 SAFE Symposium, New Orleans, LA, December 4-8, 1989.
5. Bement, Laurence J.; Doris, Thomas A.; and Schimmel, Morry L.: Output Testing of Small-Arms Primers. Presented at the 1990 SAFE Symposium, San Antonio, TX, December 11-13, 1990.
6. Bement, Laurence J.; Schimmel, Morry L.; and Bailey, James W.: Ignitability Test Method and Apparatus. Patent 5,052,817, October 1, 1991.

TABLE I - CHEMICAL COMPOSITION OF MIX (FA #874), ASSEMBLY
NOTES AND PROPERTIES FOR M52A3B1 PRIMER

<u>Ingredients</u>	<u>% Dry Weight</u>
Acetylene Black, Spec MIL-A-3850	.75 +/- .25
Barium Nitrate, Spec MIL-B-162, Type II	44.25 +/- 2.50
Calcium Silicide, Spec MIL-C-324, Type II	13.00 +/- 2.50
Acacia, Technical (gum Arabic)	1.00 +/- .25
Lead Styphnate, Spec MIL-L-757	40.00 +/- 2.5
2,4,6 Trinitroresorcinol (TNR)	1.00 +/- .25

Assembly Notes and Properties

1. Primer mix consolidated wet (2 to 4% water) at a minimum of 7,500 psi and minimum dwell time of 0.050 second.
2. Total dry weight in grams of 0.1459 minimum, 0.1945 maximum.
3. Electrical resistance: maximum 1,200,000 ohms minimum 1,000 ohms
4. Electrical sensitivity: 100% firing voltage at 160 volts, DC.
5. Action time of primer assembled in cartridge shall not exceed 3.5 milliseconds.

TABLE II - CHEMICAL COMPOSITION AND PROPERTIES OF WC872 GUN PROPELLANT

Ingredients	% Dry Weight
Nitrocellulose	Remainder (about 80%)
Total Volatiles	2.00% Maximum
Dinitrotoluene	1.0% Maximum
Moisture/Volatiles	0.75 - 1.25%
Dibutylphthalate	5.5 - 9.5%
Sodium Sulfate	0.50% Maximum
Calcium Carbonate	1.00% Maximum
Nitroglycerine	8.00 - 11.00%
Diphenylamine	0.75 - 1.50%
Residual Solvent	1.20% Maximum
Dust & Foreign	0.10% Maximum
Graphite	0.4% Maximum
Potassium Nitrate	0.10 - 1.50%
Potassium Sulfate	0.1% Maximum
Properties	
Bulk Density (gm/cc)	0.945 - 1.025
Granulation	(Flake, 0.04 DIA X 0.02 inch)
US Sieve	
16	95% of the material passes through, minimum
18	Material remains on the screen
20	ditto
25	ditto
30	ditto
18 to 30	90% of the material remains on, minimum
30	5.0% of the material passes through, maximum
35	3.0% of the material passes through, maximum
Thermal Stability	120°C, 5 hours Minimum

TABLE III - APPROACH FOR DETERMINING THE AVERAGE CRITICAL VOLTAGE AND STANDARD DEVIATION FOR ARMY PRIMER SENSITIVITY TESTS.

<u>No. Firing</u>	<u>No. No-Fire</u>	<u>Voltage Increment</u>	<u>Fraction No-Fire (Pi)</u>	<u>Std. Dev. Factor (Ki)</u>	<u>KiPi</u>
			XXXXXXXXXXXXXXXXXXXXXXXXXXXX	1	
				3	
	(See Table IVB for an example of data compilation)			5	
				7	
				9	
				11	
				13	
				15	
				17	
				19	

Totals

The average critical voltage (V) and standard deviation are calculated as follows:

$$V = (\text{Sum of } P_i) (m) + (V_{100\%} + m/2)$$

$$sd = (sd') m$$

$$sd' = [(\text{sum of } K_i P_i) - (\text{sum of } P_i)^2]^{1/2}$$

Where:

V = the average critical voltage at which 50% of the primers fire and 50% of the primers misfire

P_i = Decimal fraction of primers misfiring at each individual voltage

m = Voltage interval of test; in this case it was 10

V_{100%} = First voltage at which all primers in a sample misfire at voltage levels of 30, 20 or 10. If a misfire occurs at 10 volts, this value shall be 0.

K_i = Variance factor, numbered 1, 3, 5, 7, etc., is a statistical weighting factor, related to the sequence of voltage increments where failures occurred.

TABLE IVA - RESULTS OF ARMY PRIMER SENSITIVITY TESTS FOR THREE
 GROUPS OF M52A3B1 PRIMERS
 (2 UF CAPACITOR, LABORATORY AMBIENT)

(10 units per voltage)

Applied voltage	Control	Half Load	No Calcium Silicide
	Fire/No-Fire	Fire/No-Fire	Fire/No-Fire
10	0/10	0/10	0/10
20	1/9	0/10	0/10
30	2/8	0/10	0/10
40	4/6	1/9	0/10
50	10/0	4/6	0/10
60	10/0	5/5	0/10
70	10/0	7/3	1/9
80	10/0	10/0	0/10
90	10/0	9/1	2/8
100	10/0	10/0	5/5
110	10/0	10/0	5/5
120	10/0	10/0	7/3
130	10/0	10/0	8/2
140	10/0	10/0	10/0
150	10/0	10/0	9/1
160	10/0	10/0	10/0
Avg. Crit. Volt.	38	58	107
Standard Dev.	10.0	14.2	20.4
Avg. Crit. Volt. + 3 Std. Dev.	68.0	100.1	168.2

TABLE IVB - RESULTS OF ARMY PRIMER SENSITIVITY TESTS FOR THREE GROUPS OF M52A3B1 PRIMERS (2 UF CAPACITOR, LABORATORY AMBIENT)

An example, using the No Calcium Silicide data, for the calculation of Average Critical Voltage and standard deviation follows:

<u>Number Fires</u>	<u>Number No-Fires</u>	<u>Voltage Increment</u>	<u>Fraction No-Fire (Pi)</u>	<u>Std. Dev. Factor (Ki)</u>	<u>KiPi</u>
0	10	30	XXXXXXXXXXXXXXXXXXXXXXXXXX		
0	10	40	1.0	1	1.0
0	10	50	1.0	3	3.0
0	10	60	1.0	5	5.0
1	9	70	0.9	7	6.3
0	10	80	1.0	9	9.0
2	8	90	0.8	11	8.8
5	5	100	0.5	13	6.5
5	5	110	0.5	15	7.5
7	3	120	0.3	17	5.1
8	2	130	0.2	19	3.8
10	0	140	0		
Totals			7.2		56.0

The average critical voltage (V) and standard deviation are calculated as follows:

$$\begin{aligned}
 V &= (\text{Sum of Pi}) (m) + (V100\% + m/2) \\
 &= (7.2) (10) + (30 + 10/2) \\
 &= 72 + 35 \\
 &= 107 \text{ volts}
 \end{aligned}$$

$$sd = (sd') m$$

$$\begin{aligned}
 sd' &= [(\text{sum of KiPi}) - (\text{sum of Pi})^2]^{1/2} \\
 &= [56 - (7.2)^2]^{1/2} \\
 &= [56 - 51.84]^{1/2} \\
 &= 2.04
 \end{aligned}$$

$$\begin{aligned}
 sd &= 2.04 \times 10 \\
 &= 20.4
 \end{aligned}$$

TABLE V - RESULTS OF ARMY PRIMER TIME TESTS FOR THREE GROUPS
 OF M52A3B1 PRIMERS
 (160 VOLTS/2 UF CAPACITOR, LABORATORY AMBIENT)

(Function time in microseconds)

Test	Control	Half Load	No Ca Si
1	71	94	193
2	69	99	199
3	62	101	206
4	65	105	175
5	65	100	171
6	68	88	178
7	61	109	163
8	68	89	223
9	72	96	174
10	59	103	161
11	71	106	179
12	61	119	155
13	59	108	189
14	67	106	171
15	65	111	182
16	61	96	162
17	69	109	184
18	70	140	174
19	69	114	151
20	59	117	167
Average	65.6	105.5	177.9
Std. Dev.	4.4	11.8	17.7
Average + 4 Std. Dev.	83.2	152.7	248.7

TABLE VI - RESULTS OF ARMY CARTRIDGE TESTS TO OBTAIN PRESSURE,
ACTION TIME AND PROJECTILE VELOCITY FOR THE
M52A3B1 CONTROL PRIMERS
(206 VOLTS, 4 UF CAPACITOR, -65°F, PROPELLANT STANDARD LOT 49701)

Test	Pressure psi	Action time ms	Projectile Velocity feet/sec.
1	43,400	2.573	3,289
2	43,600	2.574	3,288
3	49,200	2.523	3,318
4	44,400	2.537	3,300
5	42,000	2.558	3,262
6	53,400	-	3,314
7	41,200	2.590	3,273
8	42,600	2.560	3,300
9	42,200	2.531	3,317
10	39,600	2.557	3,271
Average	44,160	2.556	3,293
Std. Dev.	4,112	.022	20

Average action time + 4 standard deviations = 2.665 ms

TABLE VII - RESULTS OF ARMY CARTRIDGE TESTS TO OBTAIN
PRESSURE, ACTION TIME AND PROJECTILE VELOCITY FOR THE
M52A3B1 HALF LOAD PRIMERS
(206 VOLTS, 4 UF CAPACITOR, -65°F, PROPELLANT STANDARD LOT 49701)

Test	Pressure psi	Action time ms	Projectile Velocity feet/sec.
1	45,800	39.026	3,318
2	43,600	56.074	3,311
3	50,800	25.252	3,334
4	42,600	88.263	3,280
5	45,400	78.074	3,311
6	43,000	3.977	3,291
7	44,800	87.161	3,307
8	43,400	74.774	3,317
9	42,200	3.903	3,290
10	41,800	3.788	3,297
Average	44,340	46.028	3,306
Std. Dev.	2,635	35.336	16

Average action time + 4 standard deviations = 187.376 ms

TABLE VIII - RESULTS OF ARMY CARTRIDGE TESTS TO OBTAIN PRESSURE,
ACTION TIME AND PROJECTILE VELOCITY FOR THE
M52A3B1 NO CALCIUM SILICIDE PRIMERS
(206 VOLTS, 4 UF CAPACITOR, -65°F, PROPELLANT STANDARD LOT 49701)

Test	Pressure psi	Action time ms	Projectile Velocity feet/sec
1	38,800	2.722	3,218
2	40,400	2.738	3,221
3	43,400	2.711	3,267
4	41,000	2.718	3,259
5	47,400	2.632	3,282
6		Misfire	
7	48,200	2.575	3,303
8	42,200	2.663	3,287
9	46,800	2.604	3,294
10	46,200	2.575	3,313
*Average	43,822	2.660	3,272
Standard Dev.	3,431	.065	34

Average action time + 4 standard deviations = 2.924 ms, *Excluding the misfire

TABLE IX - COMPILATION OF RESULTS OF ARMY CARTRIDGE TESTS TO
OBTAIN PRESSURE, ACTION TIME AND PROJECTILE VELOCITY
FOR THREE GROUPS OF M52A3B1 PRIMERS
(206 VOLTS, 4 UF CAPACITOR, -65°F, PROPELLANT STANDARD LOT 49701)

Group	(Average)		Average Action Time + 4 std. dev. ms	Projectile Velocity feet/sec
	Pressure psi	Action time ms		
Control	44,160 4,112	2.556 .028	2.644	3,293 20
Half Load	44,340 2,635	46.028 35.336	187.372	3,306 16
*No Ca Si	43,822 3,431	2.660 .065	2.924	3,272 34

*Misfire

TABLE X - RESULTS OF IGNITABILITY TEST METHOD EVALUATION OF
M52A3B1 CONTROL PRIMERS AT LABORATORY AMBIENT AND -65°F
(160 VOLT, 2 UF CAPACITOR, PROPELLANT STANDARD LOT 49438)

Test	Ignition Time ms	Time to Peak Pressure ms	Pressure at 1 ms psi	Peak Pressure psi	Ignitability %
Laboratory Ambient					
1	.52	2.44	9,690	19,350	50.1
2	.54	2.70	9,290	18,150	51.2
3	.50	2.52	9,900	17,300	57.2
4	.46	2.68	9,600	18,900	50.8
5	.50	2.42	9,100	18,000	50.8
6	.44	2.56	9,600	17,650	54.4
7	.55	2.42	9,460	18,400	51.4
8	.49	2.58	10,000	18,800	53.2
9	.54	2.50	10,400	18,600	55.9
10	.50	2.44	10,000	20,200	49.5
Average	.50	2.53		18,535	52.4
Std. Dev.	.04	.10		844	2.5
-65°F					
1	.44	3.70	7,200	16,700	43.1
2	.52	4.08	6,600	17,950	36.8
3	.48	3.98	8,120	17,550	27.6
4	.42	3.48	8,100	17,500	46.3
5	.44	3.66	6,860	17,400	39.4
6	.40	3.43	6,790	17,250	38.8
Average	.45	3.72		17,392	38.7
Std. Dev.	.04	.26		412	6.4

TABLE XI - RESULTS OF IGNITABILITY TEST METHOD EVALUATION OF
M52A3B1 HALF LOAD PRIMERS AT LABORATORY AMBIENT AND -65°F
(160 VOLT, 2 UF CAPACITOR, PROPELLANT STANDARD LOT 49438)

Test	Ignition Time ms	Time to Peak Pressure ms	Pressure at 1 ms psi	Peak Pressure psi	Ignitability %
Laboratory Ambient					
1	.67	3.53	5,350	18,150	29.5
2	.65	3.00	6,190	17,200	36.0
3	.58	3.50	4,900	17,700	27.7
4	.78	3.22	4,670	17,100	27.3
5	.72	3.60	4,700	17,200	27.3
6	.68	3.54	5,200	17,800	29.2
7	.67	3.33	5,900	17,700	33.3
8	.59	3.46	6,100	18,000	33.9
9	.64	3.38	5,160	17,600	29.3
10	.82	3.26	5,300	17,200	30.8
Average	.68	3.38		17,565	30.7
Std. Dev.	.08	.18		371	2.8
-65°F					
1	.92	5.27	3,400	17,550	19.4
2	.80	5.00	3,600	16,650	21.6
3	.74	4.36	3,600	15,700	22.9
4	.82	4.81	4,500	17,000	26.5
5	.84	4.28	4,050	15,500	26.1
Average	.82	4.74		16,480	23.3
Std. Dev.	.07	.42		868	3.0

TABLE XII - RESULTS OF IGNITABILITY TEST METHOD EVALUATION OF
M52A3B1 NO CALCIUM SILICIDE PRIMERS AT LABORATORY
AMBIENT AND -65°F
(160 VOLT, 2 UF CAPACITOR, PROPELLANT STANDARD LOT 49438)

Test	Ignition Time ms	Time to Peak Pressure ms	Pressure at 1 ms psi	Peak Pressure psi	Ignitability %
Laboratory Ambient					
1	.52	2.58	9,400	19,350	48.6
2	.57	2.64	7,100	18,100	39.2
3	.50	2.76	8,690	19,450	44.7
4	.52	2.60	8,600	19,000	45.3
5	.56	2.52	10,490	18,700	56.1
6	.50	2.66	8,750	18,050	48.5
7	.52	2.37	10,700	19,150	52.6
8	.46	2.66	9,250	18,550	49.6
9	.50	2.62	10,010	19,400	51.6
10	.50	2.86	9,700	19,200	50.0
Average	.52	2.63		18,895	48.6
Std. Dev.	.03	.13		521	4.7
-65°F					
1	.52	4.07	5,840	16,650	35.1
2	.47	3.44	7,290	17,200	42.4
3	.40	3.42	8,750	18,300	47.8
4	.44	3.87	7,290	17,000	42.9
5	.41	3.26	8,600	17,400	49.4
Average	.45	3.61		17,310	43.5
Std. Dev.	.05	.34		619	5.6

TABLE XIII - COMPILATION OF RESULTS OF IGNITABILITY TEST METHOD
 EVALUATION OF THREE TYPES OF M52A3B1 PRIMERS AT
 LABORATORY AMBIENT AND AT -65°F
 (160 VOLT, 2 UF CAPACITOR, PROPELLANT STANDARD LOT 49438)

Group	(Average) (Standard Deviation)			
	Ignition Time ms	Time to Peak Pressure ms	Peak Pressure psi	Ignitability %
Laboratory Ambient				
Control	.50	2.53	18,535	52.4
	.04	.10	844	2.5
Half Load	.68	3.38	17,565	30.7
	.08	.18	371	2.8
No Ca Si Std. Dev.	.52	2.63	18,895	48.6
	.03	.13	521	4.7
-65°F				
Control	.45	3.72	17,392	38.7
	.04	.26	412	6.4
Half Load	.82	4.74	16,480	23.3
	.07	.42	868	3.0
No Ca Si	.45	3.61	17,310	43.5
	.05	.34	619	5.6

TABLE XIV - RESULTS OF IGNITABILITY TEST METHOD EVALUATION OF
TWO 20MM PROPELLANT LOTS AT LABORATORY AMBIENT
(160 VOLT, 2 UF CAPACITOR, PRIMER STANDARD LOT LC90H721-
225)

Test Ignitability	Primer Time ms	Ignition Time ms	Time to Peak Pressure psi	Pressure at 1 ms ms	Peak Pressure psi	%
WC872 Lot #49438						
1	-	.43	2.13	11,850	20,050	59.1
2	.02	.46	2.30	9,410	19,400	48.5
3	.03	.42	2.30	12,000	20,550	58.6
4	.03	.40	2.16	11,860	20,200	58.7
5	.01	.46	2.08	12,800	20,000	64.0
Avg.	.02	.43	2.20		20,040	57.8
Std. Dev.	.01	.03	.10		417	5.7
WC872 Lot #49450						
1	.06	.51	2.62	7,010	18,200	38.5
2	.05	.54	2.62	7,960	18,250	43.6
3	-	.48	2.84	6,800	17,700	38.4
4	.04	.53	2.40	7,940	17,850	44.5
5	.02	.68	2.35	6,900	18,400	37.5
Avg.	.04	.54	2.57		18,080	40.5
Std. Dev. Dev.	.02	.08	.20		293	3.3

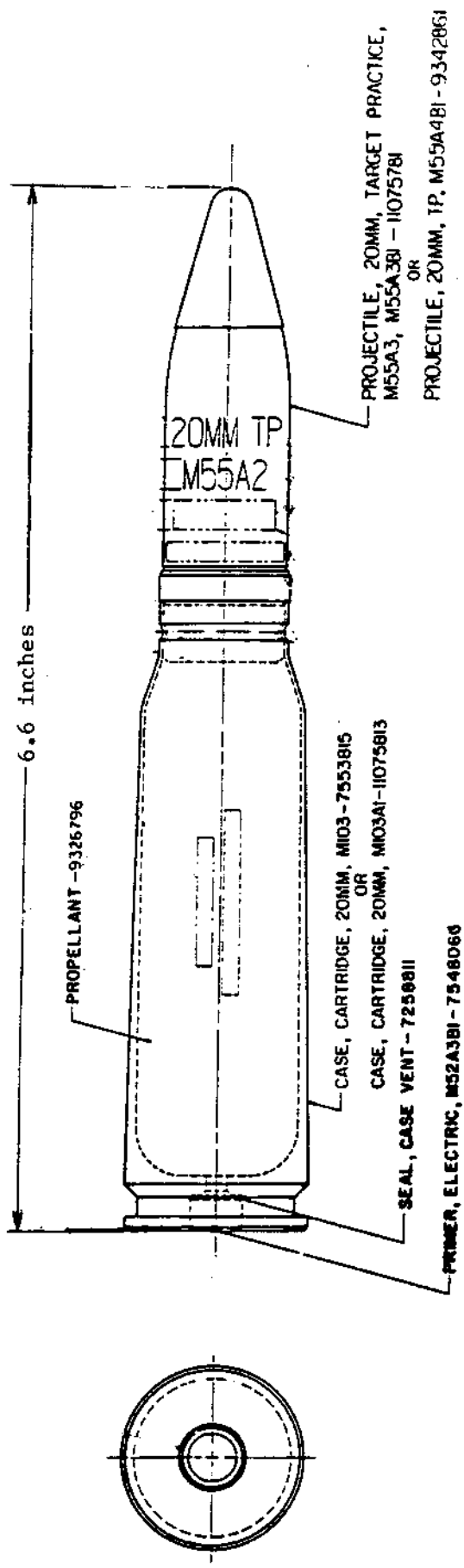

Figure 1. - Illustration of 20mm cartridge assembly.

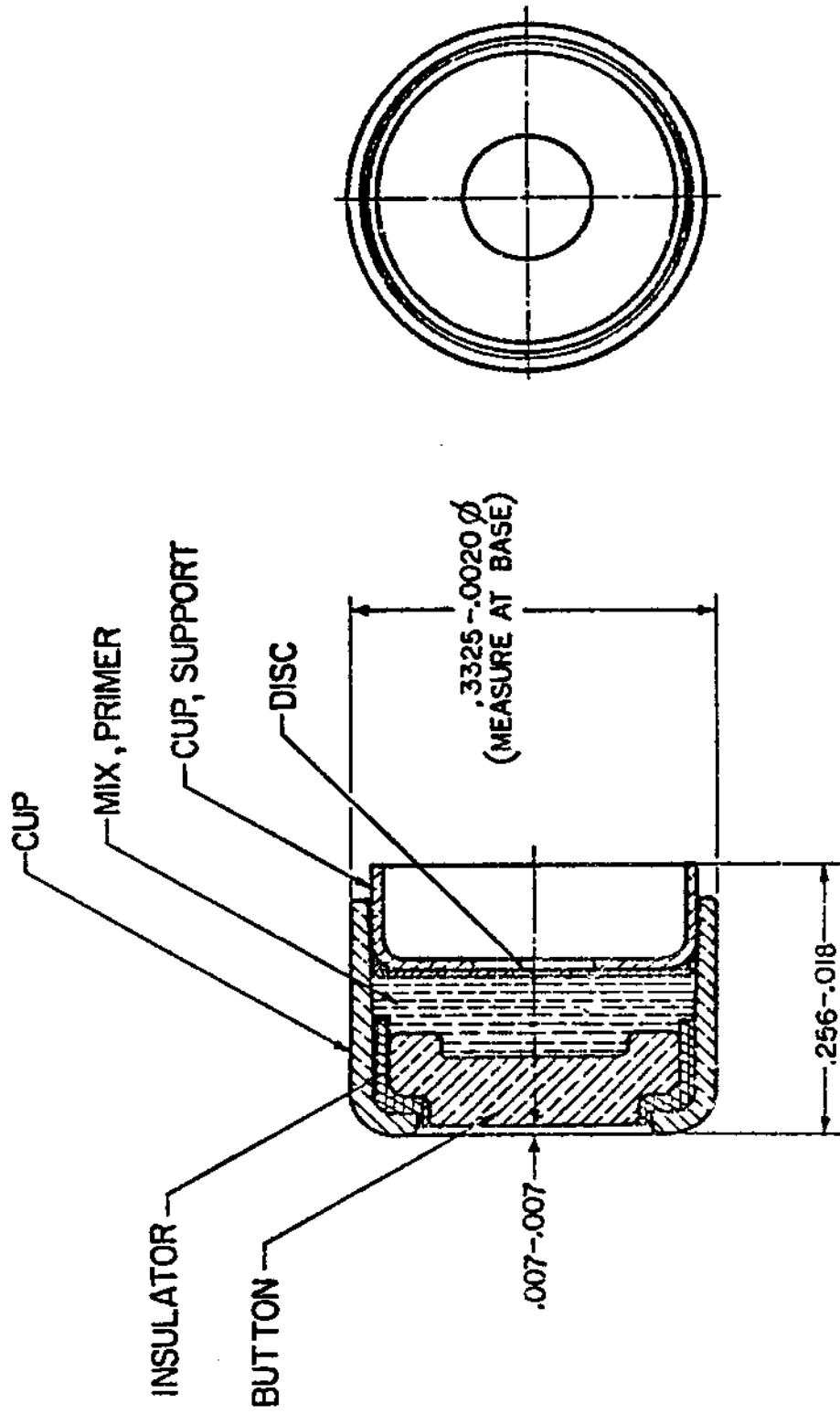

Figure 2. - Cross sectional view of 20mm electrically initiated primer, Model M52A3B1.

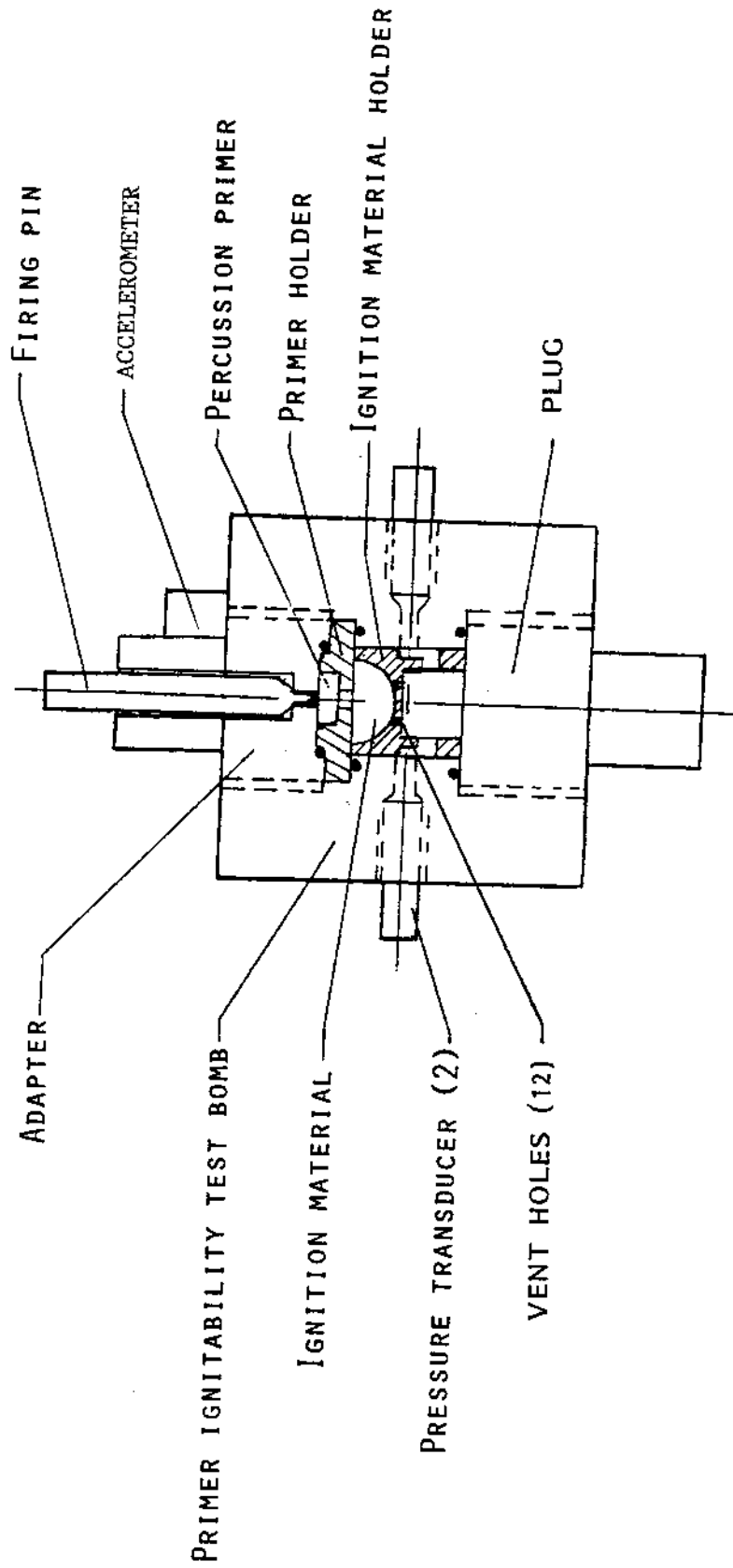
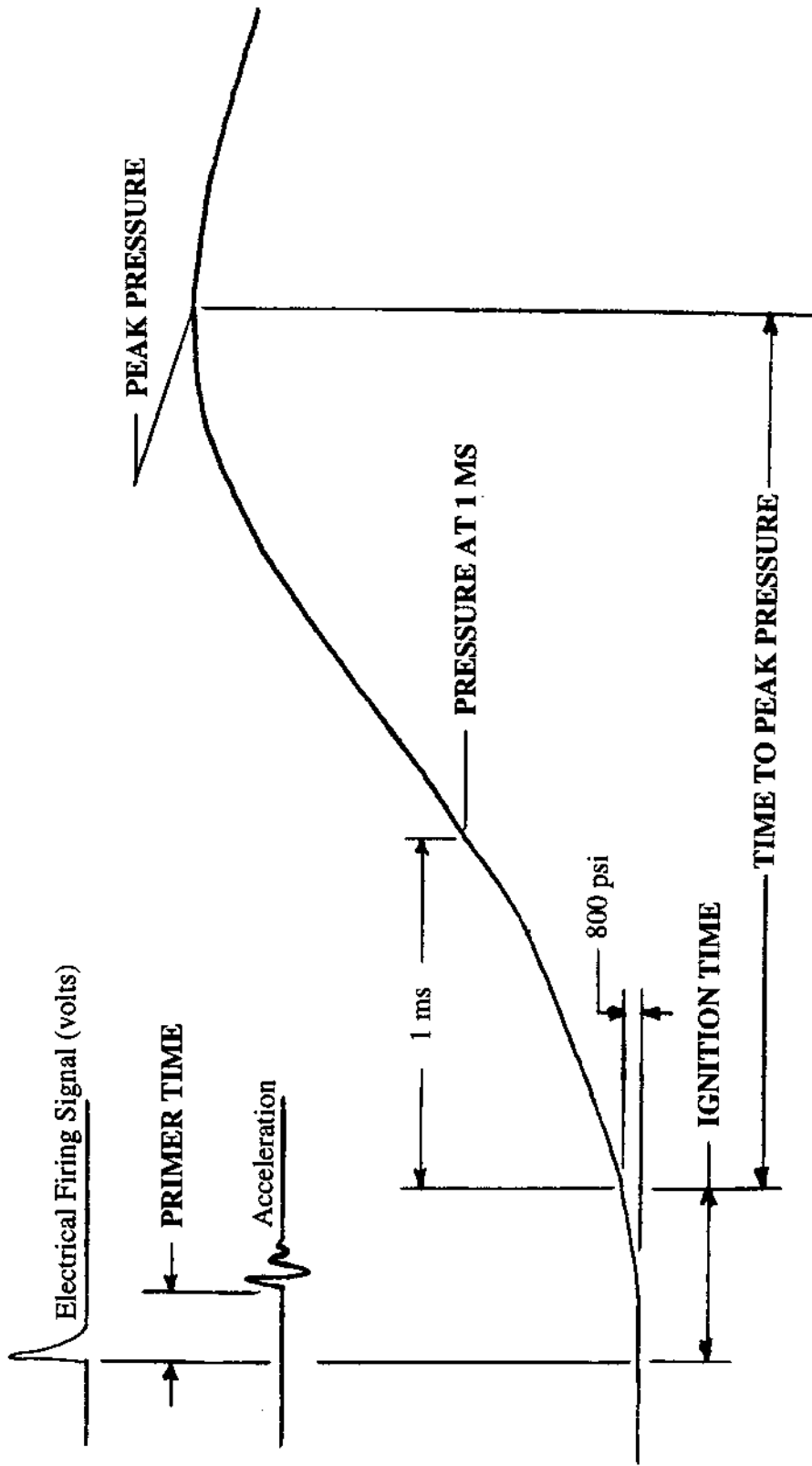

Figure 3. - Cross sectional view of apparatus for NASA Ignitability Test Method.



$$\text{IGNITABILITY} = \frac{\text{PRESSURE AT 1 MS}}{\text{PEAK PRESSURE}}$$

Figure 4. - Definitions of typical data collected (highlighted) for Ignitability Test Method.