

PILOT'S NOTES
FOR
TEMPEST V
SABRE IIA ENGINE

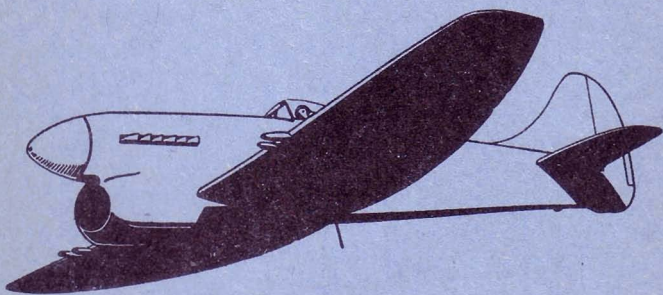

PROMULGATED BY ORDER OF THE AIR COUNCIL

[Handwritten signature]

NOTES TO USERS

THIS publication is divided into five parts: Descriptive, Handling, Operating Data, Emergencies, and Illustrations. Part I gives only a brief description of the controls with which the pilot should be acquainted.

These Notes are complementary to A.P. 2095 Pilot's Notes General and assume a thorough knowledge of its contents. All pilots should be in possession of a copy of A.P. 2095 (*see* A.M.O. A93/43).

Words in capital letters indicate the actual markings on the controls concerned.

Additional copies may be obtained from A.P.F.S., Fulham Road, S.W.3, by application on R.A.F. Form 294A, in duplicate, quoting the number of this publication in full—A.P. 2458C—P.N.

Comments and suggestions should be forwarded through the usual channels to the Air Ministry (D.T.F.).

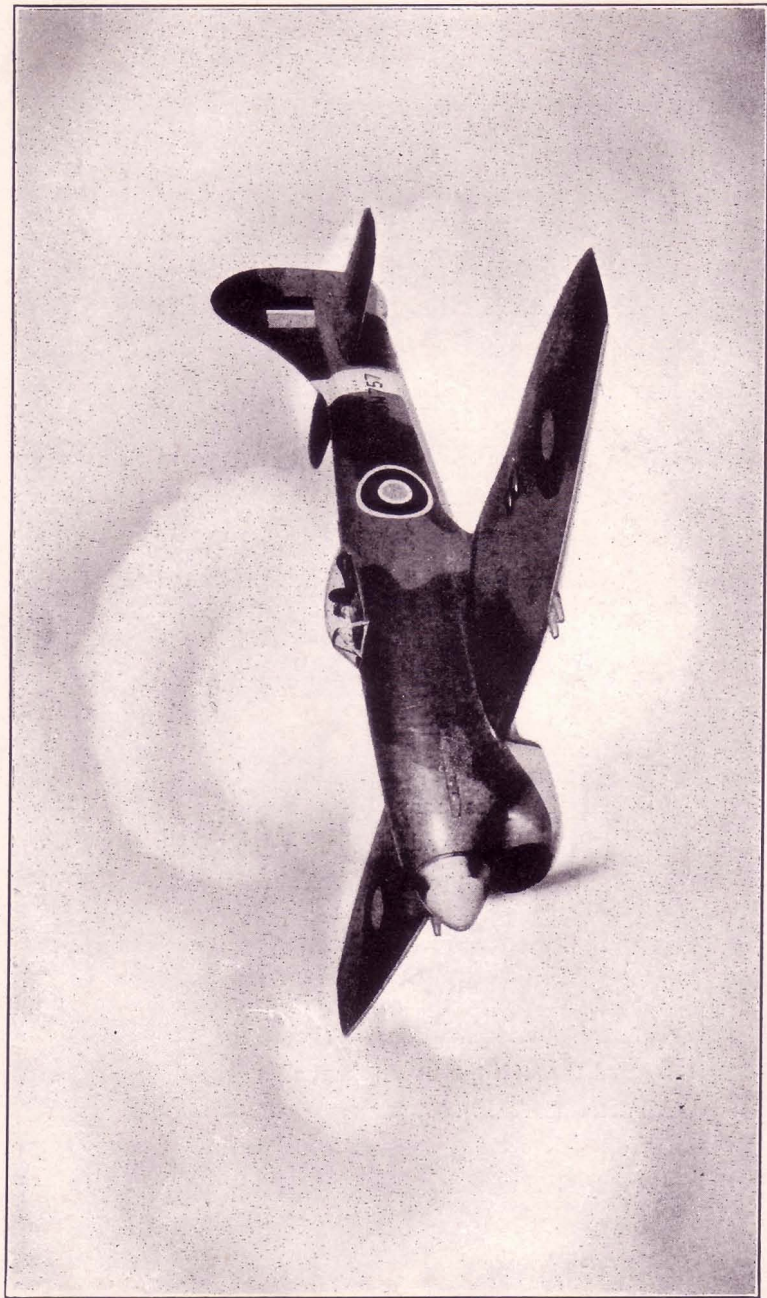

TEMPEST V

TEMPEST V PILOT'S NOTES

LIST OF CONTENTS

PART I—DESCRIPTIVE

	<i>Para.</i>
INTRODUCTION	1
MAIN SERVICES	
Fuel system	2
Oil system	3
Coolant system	4
Hydraulic system	5
Pneumatic system	6
Electrical system	7
AIRCRAFT CONTROLS	
Flying controls and locking devices	8
Trimming tabs	9
Undercarriage control	10
Undercarriage indicators	11
Undercarriage warning light	12
Undercarriage emergency release	13
Flaps control and indicator	14
Wheel brakes	15
ENGINE CONTROLS	
Throttle control	16
Propeller speed control	17
Supercharger control	18
Radiator shutter control	19
Starting and slow-running cut-out control	20
Fuel tank pressurising	21
Priming pumps	22
Ignition switches	23
Cartridge starter and booster-coil pushbuttons	24
Starter re-loading control	25
Oil dilution	26

PART I—*continued*

COCKPIT EQUIPMENT	<i>Para.</i>
Seat harness	27
Cockpit hood	28
Windscreen	29
Cockpit lighting	30
Cockpit heating	31

OPERATIONAL CONTROLS

Guns	32
Reflector gun sight	33
Camera gun	34
Radio	35

PART II—HANDLING INSTRUCTIONS

Management of the fuel system	36
Preliminaries	37
Starting engine and warming up	38
Testing the engine and installations	39
Taxying	40
Check list for take-off	41
Take-off	42
Climbing	43
General flying	44
Stalling	45
Spinning	46
Diving	47
Aerobatics	48
Check list for landing	49
Approach and landing	50
Beam approach	51
Mislanding	52
After landing	53

PART III—OPERATING DATA

Engine data: Sabre IIA	54
Flying limitations	55
Position error correction	56
Maximum performance	57
Economical flying	58
Fuel capacity and consumptions	59

PART IV—EMERGENCIES

Para.

Undercarriage emergency operation	60
Hood jettisoning	61
Ditching	62
Forced landing	63
Tyre bursting	64
Emergency equipment	65

PART V—ILLUSTRATIONS

Fig.

Instrument panel	1
Cockpit—port side	2
Cockpit—starboard side	3

PART I

DESCRIPTIVE

INTRODUCTION

1. **The Tempest V** is a single seat low wing monoplane fighter fitted with a Sabre IIA engine and a de Havilland four blade 35° hydromatic propeller.

MAIN SERVICES

2. **Fuel system**

- (i) Fuel is carried in four self-sealing tanks, one in the fuselage just aft of the engine, one in the inner portion of each wing between the main spars, and a fourth in the nose portion of the port wing. Fuel is delivered to the carburettor by an engine-driven pump. Three levers (60, 61 and 62) marked INTER SPAR, MAIN and NOSE TANK mounted on the right-hand side of the cockpit, control the fuel cocks. The cocks are closed when the levers are in the aft position.

The tank capacities are as follows :—

Main tank	76	gallons
2 Inter-spar tanks (28 gal- lons each)	56	„
Nose tank (if fitted)	<u>30</u>	„
Total	<u>162</u>	„

In addition, two auxiliary drop tanks of 45 gallons each may be carried, one under each wing.

- (ii) To meet the possibility of engine cutting due to fuel boiling in warm weather at high altitudes, the tanks can be pressurised (operative above 15,000 ft., or on later aircraft 10,000 ft.). Pressurising, however, impairs the self-sealing of tanks and should, therefore, be turned off if a tank is holed. Three fuel contents gauges are on the right-hand side of the instrument panel. They are of the direct reading type, the largest dial (19) recording the contents of the main tank, the upper window of the gauges (18) the contents of the inter-spar tanks, and the lower window (if fitted) the contents of the nose tank.

PART I—DESCRIPTIVE

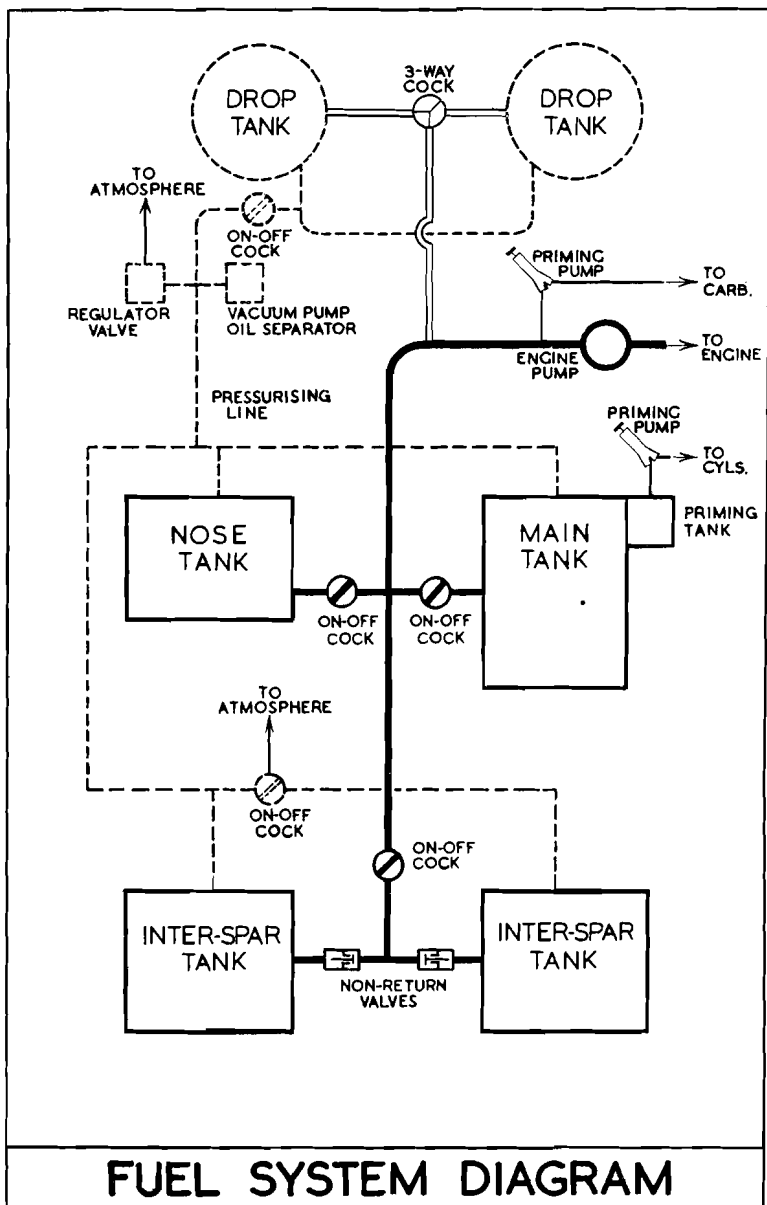

FUEL SYSTEM DIAGRAM

PART I—DESCRIPTIVE

- (iii) *Priming System:* Cylinder priming fluid consisting of a mixture of 70% fuel and 30% engine oil is contained in a tank of 5 pints capacity mounted on the starboard side of the main tank in the fuselage.
3. **Oil system.**—Oil is supplied from a tank containing 16 gallons of oil with 2 gallons air space fitted immediately aft of the fuselage fuel tank. The system incorporates a thermostatic valve which is open at oil outlet temperatures above 50° C. and an oil cooler which forms an integral part of the radiator. A separate relief valve set at 55 lb./sq.in. blow-off pressure is provided between the scavenge pump and the oil cooler to prevent possible damage to the oil cooler when starting up in cold weather. This relief valve short circuits the entire oil system and discharges into the suction side of the engine oil delivery pump.
 4. **Coolant system**—The system is thermostatically controlled, the radiator being by-passed until the coolant reaches 85° C (the thermostat is fully open at 105° C.). The radiator shutter is hydraulically controlled.
 5. **Hydraulic system.**—An engine-driven hydraulic pump which maintains a pressure of approximately 1,800 lb./sq.in., supplies the power for operating the undercarriage, the wheel doors, the wing flaps and the radiator shutter. A handpump (53) is fitted in the cockpit on the left-hand side for use in the event of engine pump failure.
 6. **Pneumatic system.**—An engine-driven compressor charging a storage cylinder supplies compressed air at 450 lb./sq.in. for operating the brakes, undercarriage assister, camera unit and gun-firing mechanism. A triple pressure gauge (26) is fitted on the left-hand side of the instrument panel.
 7. **Electrical system.**—A 24-volt engine-driven generator supplies two 12-volt accumulators for the operation of the whole electrical system. A power failure warning lamp (25) mounted on the right of the instrument panel, comes on when the generator is not charging the accumulators. There is no generator switch. The voltmeter (78) is on the electrical panel on the right-hand side of the cockpit.

PART I—DESCRIPTIVE

AIRCRAFT CONTROLS

8. **Flying controls and locking devices.**

- (i) The control column is of the spade-grip pattern and incorporates the brake lever, and gun and camera firing controls. The rudder bar is fitted with two-position rudder pedals and is adjusted for reach by a foot-operated wheel central on the rudder bar.
- (ii) The locking devices are stowed in a bag on the left-hand side of the cockpit and comprise a hinged clamp and four cables. The clamp is fitted to the control column with the projecting lugs in contact with the fork-end nuts of the aileron tie-rods, and the front two cables are hooked on to the rudder pedals. With the seat adjusting lever in the third notch from the top, the rear cables are hooked to each side of the seat and the cables tensioned by adjusting the rudder bar and then raising the seat.

9. **Trimming tabs**—The trimming tab controls are mounted on the left-hand side of the cockpit. The elevator tabs are controlled by the large handwheel (54) on the inboard side of the control box, while the rudder tab is controlled by the smaller handwheel (28) at the top of the box. Both wheels work in the natural sense and the tab position indicators are fitted between them.

10. **Undercarriage control.**—The undercarriage selector lever (49) moves in a slot on the left-hand sloping panel, marked UP in the forward and DOWN in the aft position; the knob of the lever must be turned clockwise before the lever can be moved. A safety catch (48), outboard of the lever must be pushed to FREE before the lever can be moved to UP, and automatically returns to LOCK when the lever is moved to the DOWN position.

11. **Undercarriage indicators**

- (i) The electrical visual indicator (6) on the left-hand side of the instrument panel has three green lights (for main wheels and tailwheel) and two red lights (for main wheels only). The indicator lights show:

Green .. Corresponding wheel locked down.

Red .. Corresponding main wheel between locks.

No lights .. Main wheels locked up and fairings closed.

PART I—DESCRIPTIVE

The knob in the centre should be pulled out to put the reserve set of green lights into operation and rotated to operate the anti-dazzle screen. The indicator switch (1) on the instrument panel is interlocked with the ignition switches so that the indicator must be switched ON before the ignition switches can be operated.

- (ii) The mechanical visual indicator consists of buttons which protrude through the upper surface of each wing when the corresponding wheel is down.
12. **Undercarriage warning light.**—A red light (4) on the left-hand side of the instrument panel comes on if the throttle is less than one-third open and the wheels are not locked down. No warning horn is fitted.
13. **Undercarriage emergency release.**—In the event of failure of the engine-driven pump the wheels may be lowered by the handpump. If this is ineffective, the main wheels can be lowered by gravity on releasing the mechanical up-locks by operating the two red painted foot pedals one beneath each sloping panel. The wheels travel beyond the vertical in order to lock down, and a pneumatic assister jack is incorporated in the mechanism to assist the wheels in the later stage of the operation. The control (40) for the assister jack is mounted forward of the engine control box.
The tailwheel lowers automatically on failure of the hydraulic system and locks on touching down, though the corresponding green light may not show that it has done so.
14. **Flaps control and indicator.**—The flaps are controlled by a lever (52) on the left-hand sloping panel. The lever has three positions marked UP, DOWN and VALVE SHUT. The flaps can be arrested in any desired intermediate position by returning the lever to VALVE SHUT. It is important, however, that the lever be returned to the VALVE SHUT position after the flaps have been fully lowered, as, when the flaps lever is set to DOWN the blow off pressure is lower than that required for retracting the undercarriage fully. In the event of failure of the engine-driven pump, the flaps can be operated by handpump.

PART I—DESCRIPTIVE

An indicator is fitted on the top left-hand side of the instrument panel.

15. **Wheel brakes.**—The control lever for the pneumatic brakes is fitted on the control column spade grip. A parking catch is provided. Differential control of the brakes is provided by a relay valve connected to the rudder bar. The triple pressure gauge (26) on the instrument panel shows the air pressure in the storage cylinder and at each brake.

ENGINE CONTROLS

16. **Throttle control.**—The throttle lever (35) is gated at the climb position. A bomb release switch is incorporated in the top of the lever. The friction adjuster also adjusts the friction of the propeller speed control lever.
17. **Propeller speed control.**—The control lever inboard of the throttle lever is moved forward to INCREASE REVS. The propeller is governed down to 1,600 r.p.m. to allow stretching a glide if the engine has failed but oil pressure is still available. For ground or flight operation, however, the normal minimum is 2,000 r.p.m.
18. **Supercharger control.**—The lever (33) at the rear of the engine control box is moved downward for S ratio and upward for M ratio.
19. **Radiator shutter control.**—The radiator shutter is hydraulically operated and is controlled by a lever (51) on the left sloping panel outboard of the flap control lever; movement to DOWN opens the shutter. In the event of engine-driven pump failure, the shutter can be operated by the handpump.
20. **Starting and slow-running cut-out control.**—The lever (43) on the left sloping panel has three positions: START, NORMAL and CUT-OUT. At START a stop is introduced into the throttle quadrant to give the throttle setting for starting, but a safety catch (44) beside the lever must be moved down before START can be selected. The friction adjuster for the throttle lever should be slackened off as otherwise the stop is difficult to feel.

PART I—DESCRIPTIVE

21. **Fuel tank pressurising.**—The cock control (63) is on the right-hand shelf and is turned anti-clockwise to ON.
22. **Priming pumps.**—Two 40 c.c. priming pumps are mounted one above the other on the right-hand sloping panel. The upper pump primes the engine cylinders with fluid drawn from the special tank, and the lower pump primes the carburettor with fuel from the main supply. The pump handles are released by unscrewing and should be screwed down after use.
23. **Ignition switches.**—The main switches (2) are on the left-hand side of the instrument panel and are prevented by a sliding bar from being switched on unless the undercarriage indicator switch is also on. Four ignition testing buttons are fitted in a box on the left-hand side of the cockpit above the port top longeron. If ignition trouble is suspected and there is a drop in r.p.m. when one or other of the main switches is switched off, press each button in turn and note which reproduces the drop in r.p.m. while both main switches are ON. By so doing, considerable time will be saved in locating the trouble.
24. **Cartridge starter and booster-coil pushbuttons.**—These are on the left-hand side of the instrument panel and must be depressed simultaneously in order to start the engine.
25. **Starter re-loading control.**—The toggle (77) on the right-hand shelf is used to insert the next of the five cartridges provided into the breech.
26. **Oil dilution.**—A pushbutton (76) is provided on the right-hand shelf just aft of the starter reloading control, but the system has not yet been fitted to this engine.

COCKPIT EQUIPMENT

27. **Seat harness.**—The seat harness is of a new type. All four straps can be adjusted in a similar way to the leg straps on Sutton harness. Stowage for leg straps is provided on either side of the cockpit.

PART I—DESCRIPTIVE

The harness should be adjusted so that the junction box is immediately below the parachute quick release box. No harness release is as yet provided and if for any reason the straps are loosened, care must be taken to see that they do not slip off the shoulders. (Harness release will be introduced by Mod. 103).

28. **Cockpit hood.**—The winding gear is on the port side of the cockpit. The spring-loaded knob (36) of the winder crank must be pulled inboard and held against the spring while the crank is turned. When the knob is released a pin on the bottom of the knob engages in one of the holes in a locking plate and the hood is then locked in position. Before getting out of the cockpit the knob on the crank lever should be pulled out as far as possible and turned until a projection on the knob engages a small recess on the crank lever thus holding the pin free of the holes in the locking plate and permitting the hood to be moved from the outside by hand. The hood may be locked in the closed position from outside by releasing a spring-loaded locking bolt on the outside of the starboard side panel to engage in a slot on the hood bottom rail. If the hood has been locked, the bolt must be pressed in and given a quarter turn to retain it in its depressed position or the hood cannot be fully closed from inside the cockpit.
29. **Windscreen.**—The centre panel on some early aircraft is of the dry air sandwich type. This is connected by a rubber pipe to a rubber expansion bag which is contained in a fibre cylinder fitted immediately below the windscreen. If misting occurs the pipe should be disconnected and dry air introduced before re-connecting the pipe.
30. **Cockpit lighting.**—Two lamps are fitted at the top of the instrument panel and are controlled by two dimmer switches (11 and 14) just inboard of them. A third lamp above the electrical panel is controlled by a dimmer switch at the forward end of the panel, and a fourth lamp above the trimming tab control box is controlled by a dimmer switch (45) at the top of the left-hand sloping panel. The compass light is controlled by a dimmer switch (15) on the instrument panel.

PART I—DESCRIPTIVE

31. **Cockpit heating.**—The supply of warm air to the cockpit is controlled by a lever (64) on the starboard cockpit wall: the lever is moved downwards from OFF to ON. Two ventilators are provided, one on each side of the instrument panel.

OPERATIONAL CONTROLS

32. **Guns.**—The guns are fired electro-pneumatically by the pushbutton on the control column handle; the button being turned clockwise from SAFE to FIRE. The compressed air supply is taken from the same source as the brake supply, and the available pressure is shown by the gauge on the instrument panel.
33. **Reflector gun sight.**—A reflector gun sight is mounted on a bar above the instrument panel. A dimmer switch (12) is mounted on the instrument panel and has three positions, marked OFF, NIGHT and DAY.
34. **Camera gun.**—The camera gun is mounted inside the radiator fairing and is operated by the gun-firing button on the control column, a succession of exposures being taken the whole time the button is depressed. A footage indicator and an aperture switch are mounted on a plate on the right-hand shelf; the camera master switch (70) is on the electrical panel. A separate pushbutton on the control column operates the camera gun independently of the guns. When not in use, the plug to the indicator should be put in the dummy socket on the shelf.
35. **Radio.**—The radio installation, carried behind the pilot, comprises a TR1143 and A1271 beam approach. Provision is also made for IFF equipment.

PART II

HANDLING INSTRUCTIONS

36. Management of the fuel system

(i) *Without drop tanks:*

(a) When all tanks are full, the aircraft can be taken off on any combination of tanks, but it is recommended that take-off should be made with all tanks on. The main tank should be turned off when airborne and used as a reserve; otherwise, this tank, having a gravity head, will drain first.

(b) Under no circumstances may the take-off be made on all tanks if any wing tank is less than half full. In this case the take-off must be made on the main tank only with the wing tanks isolated. Change over to the wing tanks when airborne.

(c) For normal flying, it is recommended that both inter-spar tanks and nose tanks be used together; individual tanks should be isolated only if damaged by enemy action. When all fuel has been consumed from the interspar or nose tanks the empty tanks should first be turned off and then main tank turned on. The engine will pick up on the main tank in 3 seconds if this procedure is adopted.

(d) If the main tank has been inadvertently drained first, it is imperative that it should be turned off when empty; otherwise, the engine will not pick up on the interspar or nose tanks.

(e) If at any time the engine should cut through lack of fuel, immediate action should be as follows:—

(a) Close the throttle.

(b) Check fuel contents gauge.

(c) Isolate empty tank or tanks and turn on full tank.

(d) Increase r.p.m. control to max. r.p.m.

(e) Slowly open and close throttle about one-third until engine picks up.

(f) For landing, always turn on the main tank and isolate the wing tanks if they are nearly empty.

PART II—HANDLING INSTRUCTIONS

NOTE.—Another important reason why the main tank should be saved as a reserve is that this tank, having a deep sump, will drain completely even in yaw and at steep approach angles without fear of air locking. This is not the case with the shallow wing tanks which have no sumps and are very susceptible to yawing effects.

(ii) *With drop tanks:*

(a) Maximum diving speed must not exceed 450 m.p.h. I.A.S. up to 15,000 feet. Above this height the maximum permissible diving speed is 50 m.p.h. less than the maximum permissible without drop tanks.

(b) Tanks must not be jettisoned at speeds in excess of 400 m.p.h. I.A.S. and only in straight flight. Unless the enemy is engaged, there is little point in jettisoning the tanks when dry, as this will only increase the range by 2 per cent.

(c) Spinning is not permitted.

(d) Start, warm up and take off on the main tanks with drop tanks turned OFF. At a safe height change over to the port drop tank and turn OFF all main tanks. After the port drop tank has been used turn quickly over to the starboard drop tank.

NOTE.—The engine will cut almost immediately after the fuel pressure warning light shows a drop in pressure. When flying at low altitudes, therefore, it is important to change over to the second drop tank or to the main supply tanks, when it is estimated that the drop tank in use is nearly empty and *before* the warning light comes on. The drop tanks may, however, be run dry if at a safe height sufficient to allow the engine to pick up.

(e) Should the engine not pick up after changing from port to starboard drop tank, immediately turn this tank OFF and then turn the main supply tanks ON (*see* also (i) (e) above). After ensuring that the fuel pressure is restored and the engine running satisfactorily, the starboard drop tank should be turned ON again and all the main tanks OFF.

PART II—HANDLING INSTRUCTIONS

(f) After the starboard tank has been used, first turn OFF the drop tanks and then turn ON all the main supply tanks. The main tanks should then be used in the normal manner, i.e. the interspar and nose tanks should be used first.

(g) At heights above 10,000 feet when using drop tanks the pressurising valve should be turned ON.

37. Preliminaries

- (i) On entering the cockpit check
 - Undercarriage lever DOWN
 - Undercarriage lever locking catch LOCK
- (ii) Switch on the undercarriage indicator and check that the green lights appear.
- (iii) Cockpit hood locked open.
- (iv) See that the footstep is retracted (operated by closing the top hand grip on the starboard side).

38. Starting engine and warming up

NOTE.—Before starting the engine the aircraft should be faced into wind and if a full run-up is intended the tail must be tied down. Ensure that there are no aircraft or personnel behind.

- (i) Set:
 - Ignition switches .. OFF
 - Fuel All tanks ON (*see* Para. 36)
 - Flaps Up (selector at VALVE SHUT)
 - Propeller speed control Fully forward
 - Supercharger control .. M (up)
 - Radiator shutter .. DOWN
- (ii) Check that there is not a live cartridge in the firing position, then have the engine turned through three or four revolutions to ensure that it is free.
- (iii) *Starting*.—The pilot must obtain an affirmative visual “all clear” signal before firing each cartridge.

WARNING—There is a possibility of sleeve seizure when starting a cold engine. This will be indicated by the rotation of the propeller becoming less as each cartridge is fired.

PART II—HANDLING INSTRUCTIONS

- (a) Set the cut-out lever to START.
- (b) Open the throttle gently to the stop.
- (c) Prime the carburettor until the fuel pressure warning light goes out. Then screw down the pump.
- (d) Load the cartridge starter. The following types of cartridge should be used.

At air temperatures above $+5^{\circ}$ C. No. 2 Mark II
,, ,, ,, below $+5^{\circ}$ C. No. 3 Mark I

- (e) Switch ON the ignition.
- (f) Carefully operate the cylinder priming pump until increased resistance is felt, and then prime the cylinders with full vigorous strokes as follows:

Oil temperature	No. of strokes
0° C. to $+10^{\circ}$ C.	5
$+10^{\circ}$ C. to $+20^{\circ}$ C.	4
$+20^{\circ}$ C. to $+30^{\circ}$ C.	3

If the engine has been standing less than half an hour, or if over half an hour and the oil temperature is still above $+30^{\circ}$ C., prime with one stroke only.

- (g) Immediately after priming, press the booster-coil and starter buttons simultaneously. Keep the booster-coil pushbutton depressed and as the engine fires operate the priming pump with short sharp strokes, if and as required, until the engine is running steadily. Stop priming if white smoke issues from the exhaust stubs.

NOTE.—Do not jerk the throttle if the engine fails to pick up, as no useful purpose is served and the air intake will be flooded with fuel, probably leading to a fire.

- (h) As soon as the engine is running steadily depress the priming pump slowly, and screw it down. Release the booster-coil pushbutton and return cut-out lever to NORMAL.

- (j) If the engine fails to start at the first attempt, it must not be primed again until it fires on a subsequent attempt. Once the engine has fired, prime vigorously until the engine is running steadily.

PART II—HANDLING INSTRUCTIONS

NOTE.—If the engine fails to start after three cartridges have been fired, switch off, and blow the engine out and recommence at sub-para. (a). Priming of the engine on starting is limited to 15 full strokes of the priming pump, after which, if the engine fails to start, the cylinders must be primed with oil.

- (iv) *Fire* : If the engine catches fire the following drill must be carried out:
- (a) Ground personnel shout “ FIRE ”.
 - (b) The pilot must switch OFF the ignition immediately and then extend both arms outside the cockpit to indicate that the engine is safe.
 - (c) When the man with the extinguisher sees that the pilot has his arms extended he must immediately apply the extinguisher to the air intake.
- (v) Run the engine at 1,000 r.p.m. and check that it is functioning normally. Maintain this speed until the oil pressure falls below 100 lb./sq.in.
- (vi) With the oil pressure below 100 lb./sq.in. increase engine speed progressively to 2,000 r.p.m. and test each magneto as a precautionary check.
- (vii) Warm up at 2,000 r.p.m. until the oil temperature reaches 40° C.

39. Testing the engine and installations

NOTE.—It is important that the engine be allowed to warm up properly before being opened up for ground checks. The engine should normally not be opened up before the oil temperature has reached a minimum of 40° C.

While warming up

- (i) Make the usual checks of temperatures, pressures and controls.
- (ii) Check pneumatic pressure (normal supply 450 lb./sq.in.). If the pressure is low, ensure that the pump is definitely building up pressure, if not, the aircraft should not be flown.

PART II—HANDLING INSTRUCTIONS

- (iii) Check hydraulic system by lowering and raising flaps; ensure that selector is returned to VALVE SHUT.

After warming up

NOTE.—The following comprehensive checks should be carried out after repair, inspection (other than daily), or at the pilot's discretion, and the tail *must* be tied down. Normally they may be reduced in accordance with local instructions, and the tail need not be tied down if r.p.m. do not exceed 2,800.

- (iv) Open up to zero boost and check operation of the two-speed supercharger once only. R.p.m. should fall when S ratio is engaged.
- (v) Exercise and check operation of propeller speed control at least twice, as follows :
- (a) Set control fully forward and close throttle to obtain 2,400 r.p.m.
- (b) Set control back to the positive coarse pitch position.
- (c) When the r.p.m. have dropped to $1,600 \pm 50$ move the control to the fully forward position. R.p.m. should rise to 2,400 r.p.m.
- (vi) With the propeller control fully forward open the throttle lever fully and check take-off boost and static r.p.m.
- (vii) Throttle back to maximum rich continuous boost and test each magneto in turn. The drop in r.p.m. should not exceed 50.

40. Taxiing

The brakes are powerful and should be used with care.

41. Check list for take-off

- (i) T — Trimming tabs .. Elevator: $1\frac{1}{2}$ divs. nose down
Rudder: full port
- P — Propeller Fully forward
- F — Fuel Check cock settings (*see* Para. 36)
- F — Flaps Up (lever at VALVE SHUT)
- Supercharger .. M ratio
- Radiator shutter DOWN
- (ii) Open up the engine to 2,500 r.p.m. to clear it and then if necessary wipe the oil off the outside of the windscreen.

PART II—HANDLING INSTRUCTIONS

42. Take-off

- (i) Full throttle may be used for take-off, but there is little reduction in take-off run if more than +4 lb./sq.in. boost is used.
- (ii) The take-off run is reduced by approximately 100 yards by using between 20° and 30° of flap, although when using flap for take-off there is a greater tendency to swing to the right.
- (iii) Retract the undercarriage as early as possible after take-off. Should the undercarriage red lights fail to go out, throttle back and reduce speed to about 145-150 m.p.h. when the deceleration will allow the wheels to lock UP. If flaps are used for take-off they should be raised at a safe height (200 feet). The undercarriage red lights may fail to go out until the flaps are fully up.

43. Climbing

- (i) The recommended speed for climb is 185 m.p.h. I.A.S. up to 20,000 feet.
- (ii) For maximum rate of climb at climbing power, change to S ratio when boost has dropped by 3 lb./sq.in. (about 10,000 feet).

44. General flying

- (i) *Stability*.—The aircraft is stable directionally and laterally, but is slightly unstable longitudinally.
- (ii) *Controls*.—The aileron control remains effective up to the maximum permissible speed, but is sluggish at low speeds. The rudder should be used firmly for going into a turn or when reversing a turn. The elevator is light and effective, but with flaps and undercarriage down response becomes rather sluggish.
- (iii) *Change of trim*

Flaps DOWN	Nose down
Undercarriage DOWN	Nose down
Radiator shutter UP	Slightly nose down

PART II—HANDLING INSTRUCTIONS

Directional trim changes with variation in airspeed and throttle setting, and full use should be made of the rudder trimming tab to avoid flying with sideslip. This tab, however, is very sensitive and should, therefore, be used gently. Fore and aft trim is affected by changes in directional trim: left yaw produces a tendency for the nose to drop, and right yaw for the nose to rise.

- (iv) *Flying at reduced speed.*—Reduce speed to 200 m.p.h. I.A.S. and lower flaps 20°. Set the propeller speed control to 3,150 r.p.m. and fly at about 170 m.p.h. I.A.S.

45. Stalling

Stalling speeds at 11,500 lb. are:

Flaps and undercarriage up	85 m.p.h. I.A.S.
„ „ „ down	75 m.p.h. I.A.S.

- (i) There is no warning of the stall at which the left wing drops sharply.
- (ii) *High speed stall.*—If excessive “g” is applied in a turn or recovery from a dive, the ailerons “snatch” and experience shows that either wing may drop: with further backward movement of the control column the aircraft will become inverted and finally spin. The aircraft responds immediately if recovery action is initiated when aileron “snatch” occurs.

46. Spinning

Spinning is *not permitted* pending results of spinning trials. Recovery from inadvertent spins to be in accordance with A.P. 129 Flying Training Manual, Chapter III, paras. 197-205.

47. Diving

- (i) Before diving make certain that the radiator shutter is UP. A strong nose-down pitch results from closing the shutter in a dive.

PART II—HANDLING INSTRUCTIONS

- (ii) If a dive is to be continued below 10,000 feet, select M ratio before commencing the dive. The throttle should not be fully closed.
- (iii) In the dive the aircraft tends to become tail heavy but no retrimming is necessary. The elevator trimming tabs are very sensitive and should therefore not be used when diving.
- (iv) As speed increases the aircraft tends to yaw to port. This should be corrected by use of the rudder trimming tab, but as this control is sensitive, it must be used slowly and gently.

48. Aerobatics

All the normal aerobatics are easy to perform, but a large amount of height may be gained or lost during some manœuvres and an ample margin must be allowed. Particular care should be taken diving out from a half-roll. Such a manœuvre should not be attempted below 10,000 feet if the speed is above 250 m.p.h. I.A.S. at the commencement.

Looping.—Use maximum climbing power and start the loop at a speed of at least 380 m.p.h. I.A.S. Care must be taken to avoid any harsh backward movement of the control column as this may induce a high speed stall.

Rolling.—Speed should be at least 250 m.p.h. I.A.S. and the roll sufficiently “barrelled” to keep the engine running and avoid any risk of loss of oil pressure.

Half roll off loop.—Maximum climbing power should be used and the speed should be not less than 400 m.p.h. I.A.S. when starting the loop.

Upward roll.—Maximum climbing power should be used and the speed at the bottom of the dive should be

PART II—HANDLING INSTRUCTIONS

about 400 m.p.h. I.A.S. for a fairly steep climbing roll, and 450 m.p.h. I.A.S. or more for a vertically upward roll.

Flick manœuvres are not permitted.

49. Check list for landing

- (i) Turn on main tank, isolate wing tanks if nearly empty.
- (ii) Reduce speed to 200 m.p.h. I.A.S. and check brake pressure.
 - U — Undercarriage .. DOWN (check wing indicators and green lights, and warning light).
 - P — Propeller control .. Fully forward.
 - Supercharger .. M ratio
 - Flaps Fully down (and lever to VALVE SHUT)
 - Radiator shutter .. DOWN (UP if temp. low)
- (iii) A tendency to yaw and pitch is noticeable as the undercarriage comes down.
- (iv) The flaps are large and the rate of descent with them lowered is consequently rapid.

50. Approach and landing

Approach speeds in m.p.h. I.A.S. are as follows:

			(Flaps up)
Engine assisted	100		120
Glide	120		130

NOTE.—Do not turn at speeds below 130–140 m.p.h. I.A.S.

PART II—HANDLING INSTRUCTIONS

51. Beam approach

	Preliminary Approach	Inner Marker on Q.D.R.	Outer Marker on Q.D.M.	Inner Marker on Q.D.M.
Indicated height (feet)	1,500	1,000	700-800	150
Action	Lower 20° flap	Lower undercarriage and radiator flap	Lower full flap	Throttle back slowly
Resultant change of trim	Nose down	Slight nose down	Slight nose down	Slight nose down
I.A.S. m.p.h.	170	160-170	120	110-115
R.p.m.	3,150	3,150	3,500	3,500
Boost (level flight)	- 4	- 2	- ½	-
Boost (- 500 ft./min.)	- 4½ approx.	- 3	- 3	-
Boost (overshoot)	-	-	-	+ 6
Remarks	Reduce speed to below 200 I.A.S. before lowering 20° flap—retrim rudder			OVERSHOOT Retrim. Undercarriage up. Flaps up in stages at 400 ft. Nose up change of trim and swing to right
Altimeter error at take-off minus 50 feet				
Altimeter error at touch-down minus 90 feet				
Add 3.2 millibars to Q.F.E. to give zero reading at touch-down.				

PART II—HANDLING INSTRUCTIONS

52. **Mislanding**

- (i) The aircraft will climb away easily with undercarriage and flaps down, and the use of full take-off boost is unnecessary.
- (ii) Open the throttle slowly to about - 4 lb./sq.in. boost and counteract the tendency to swing right by firm use of the rudder.
- (iii) Before the undercarriage is raised, the flaps selector must be at the VALVE SHUT position, otherwise the undercarriage will not retract fully.
- (iv) Climb at 140-150 m.p.h. I.A.S. and raise the flaps in stages at about 200 feet. The flaps come up slowly.

53. **After landing**

- (i) Before taxiing raise the flaps and set radiator shutter DOWN (if landing has been made with radiator shutter UP).
- (ii) Change to S ratio once and back to M ratio.
- (iii) To stop the engine, open up to 1,000 r.p.m. until blue smoke ceases to issue from the exhaust stubs, indicating that surplus oil has been expelled. Operate the CUT-OUT lever with the throttle set at the 1,000 r.p.m. position
- (iv) When the engine has stopped, switch OFF the ignition and turn off fuel: return cut-out lever to NORMAL.

NOTE.—Starter cartridges should be removed overnight to avoid deterioration.

PART III

OPERATING DATA

54. **Engine data:** Sabre IIA.

- (i) *Fuel*—100 octane only.
- (ii) *Oil*.—See A.P. 1464/C37.
- (iii) *Engine limitations*.—The *maximum* permissible r.p.m., boost and temperatures for the conditions of flight and periods stated are as follows:

		R.p.m.	Boost lb./sq.in.	Temp. °C. Coolant	Oil
TAKE-OFF					
TO 1,000 FT.	M	3,700	+7	—	—
CLIMBING	M	} 3,500 (3,700)	+6(+7)	125	90
1 HR. LIMIT	S				
RICH	M	} 3,150	+4½	110	80
CONTINUOUS	S				
WEAK	M	} 3,150	—3	110	80
CONTINUOUS	S				
COMBAT	M	} 3,700	+7(+9)	130	95
5 MINS. LIMIT	S				

Figures in brackets apply to engines embodying Mod. Sabre 158 or 297 and Mod. Sabre 276.

OIL PRESSURE:

NORMAL 60–90 lb./sq.in.
EMERGENCY MINM. (5 MINS.) .. 50 „

MINM. TEMP. FOR TAKE-OFF:

OIL: NORMAL TAKE-OFF 40° C.
OPERATIONAL NECESSITY 20° C.
COOLANT 65° C.

FUEL PRESSURE 2½ lb./sq.in.

- (iv) *Supercharger gear change*.—Gear changes between 10,000 and 12,000 feet may be made at 3,500 r.p.m., but at all other altitudes and for ground checks r.p.m. must not exceed 3,150. Gear changes may, however, be made at 3,700 r.p.m. when in contact with the enemy, on engines with increased climb rating.

SABRE II A

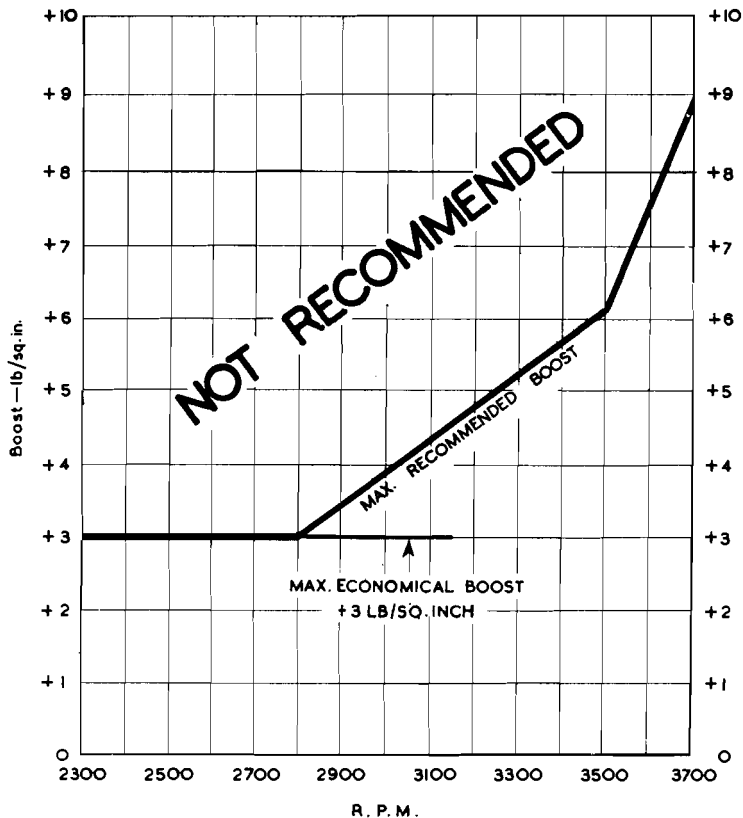

PART III—OPERATING DATA

55. Flying limitations

The aircraft is designed for the following speeds:

		m.p.h.	I.A.S.
Diving below 30,000 ft.	370
„ „ 25,000 ft.	410
„ „ 20,000 ft.	450
„ „ 15,000 ft.	490
„ „ 10,000 ft.	540
Hood open	300
Undercarriage down	215
Flaps down	160

For restrictions when carrying drop tanks, see Para. 36.

56. Position error corrections

(i) *Airspeed indicator*

From	120	160	200	240	280	320	360	} m.p.h. I.A.S.
To	160	200	240	280	320	360	400	
Add	2	—	—	—	—	—	—	} m.p.h.
Subtract	—	2	6	10	14	18	22	

(ii) *Altimeter*

From	200	250	290	320	350	} m.p.h. I.A.S.
To	250	290	320	350	390	
Subtract	100	200	300	400	500	feet

57. Maximum performance

(i) *Climbing*.—The speeds for maximum rate of climb are as follows:

S.L. to 20,000 feet	185 m.p.h. I.A.S.
20,000 to 24,000 feet	175 m.p.h. I.A.S.
24,000 to 27,000 feet	165 m.p.h. I.A.S.
27,000 to 29,000 feet	160 m.p.h. I.A.S.
29,000 to 31,000 feet	155 m.p.h. I.A.S.
31,000 to 33,000 feet	150 m.p.h. I.A.S.
Above 33,000 feet	145 m.p.h. I.A.S.

Change to S ratio when the boost has dropped to +3 lb./sq.in. with the throttle fully open.

(ii) *Combat*.—Change to S ratio when the boost has dropped to +4 lb./sq.in. with the throttle fully open.

PART III—OPERATING DATA

58. Economical Flying

- (i) *Climbing*.—Use $+3$ lb./sq.in. boost and 3,150 r.p.m. at the speed recommended for maximum rate of climb. Change to S ratio when the boost has fallen to $+2$ lb./sq.in.
- (ii) *Cruising*.—To obtain any required I.A.S. the lowest possible r.p.m. should be used, provided the boost does not exceed -3 lb. sq.in. R.p.m. down to 2,000 may be used, but it may be found that the engine will not run smoothly below about 2,150. S gear should not be used at heights at which the required speed can be obtained without exceeding 3,150 r.p.m. in M gear.
- (iii) *Maximum range*.—The recommended speed is 210 m.p.h. I.A.S. reducing to 190 m.p.h. I.A.S. at 20,000 feet and above. At low altitudes boost should not be reduced below $-3\frac{1}{2}$ lb./sq.in., even though 210 m.p.h. I.A.S. is thereby exceeded.
- (iv) *Maximum endurance*.—Use the lowest possible r.p.m. and the lowest boost at which height can be maintained. The best speed is about 180 m.p.h. I.A.S. but at low altitudes boost should not be reduced below $-4\frac{1}{2}$ lb./sq.in., even though 180 m.p.h. I.A.S. is thereby exceeded.

59. Fuel capacity and consumptions

(i) *Fuel capacity* :

Main tank	76	gallons
Inter-spar tanks (28 gallons each) ..	56	,,
Nose tank (if fitted)	30	,,
Total	162	,,

(ii) *Fuel consumptions* (approx. gals. hr.)

(a) *Weak mixture*

PART III—OPERATING DATA

M ratio at 5,000 feet.

Boost lb./sq.in.	R.P.M.				
	3,150	2,900	2,700	2,500	2,300
+3	100	91	84	—	—
+1 $\frac{3}{4}$	91	84	78	72	66
+1	—	—	—	—	63
0	—	—	—	—	58
-2	—	—	—	—	49
-4	—	—	—	—	42

M ratio at 15,000 feet.

Boost lb./sq.in.	R.P.M.				
	3,150	2,900	2,700	2,500	2,300
0	94	—	—	—	—
-1	87	79	—	—	—
-2	80	74	69	63	—
-3	74	68	63	59	—
-4	67	62	58	54	49

S ratio at 25,000 feet

Boost lb./sq.in.	R.P.M.					
	3,150	3,000	2,900	2,800	2,700	2,600
0	94	—	—	—	—	—
-1	—	86	—	—	—	—
-1 $\frac{1}{2}$	—	—	81	—	—	—
-2	—	—	—	75	—	—
-3	—	—	—	—	70	—
-3 $\frac{3}{4}$	—	—	—	—	—	64

(b) *Rich mixture*

Boost lb/sq.in.	R.p.m.	M ratio at 5,000 ft.	S ratio at 15,000 ft.
+7	3,700	190	190
+6	3,500	150	165
+4 $\frac{1}{2}$	3,150	125	132

PART III—OPERATING DATA

AIR MILES PER GALLON

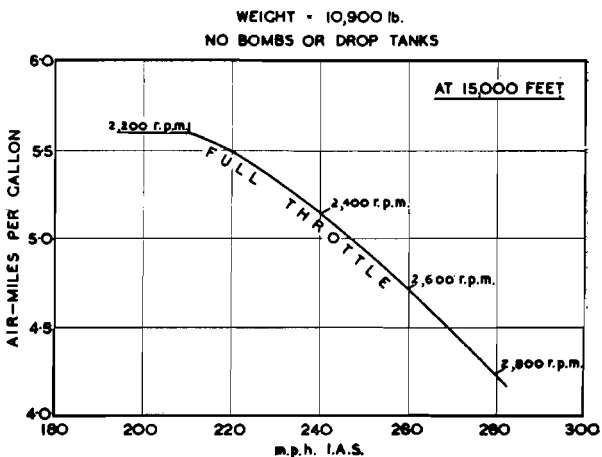
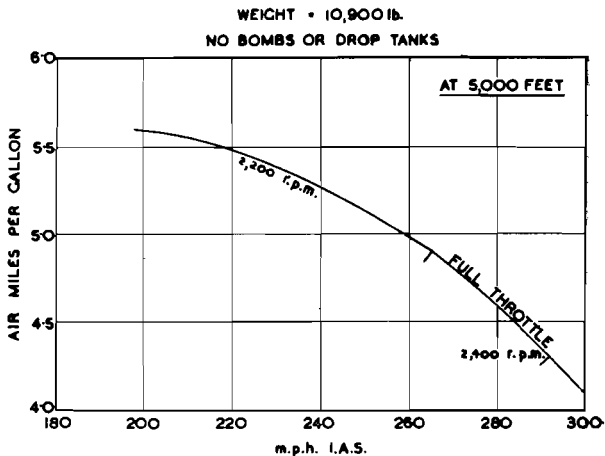

PART III—OPERATING DATA

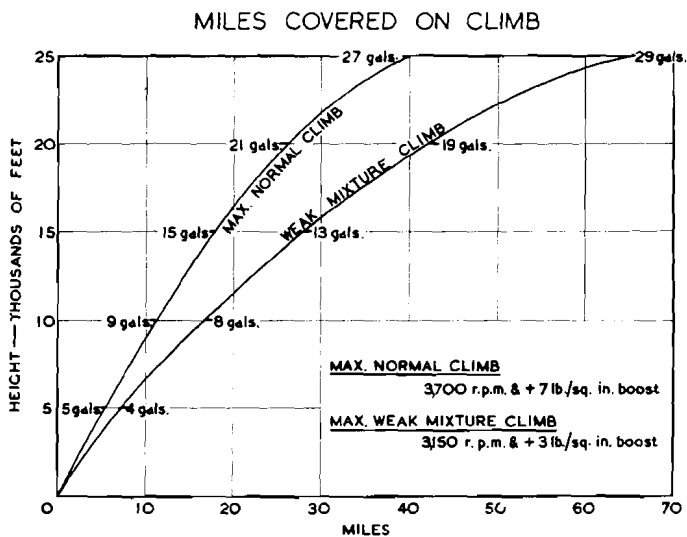

PART IV

*EMERGENCIES*60. **Undercarriage emergency operation**

If after selecting DOWN the red indicator lights do not come on, and the engine pump will not lower the undercarriage, the handpump or emergency release pedals and assister valve must be used as follows:

- (i) Leave the undercarriage selector lever DOWN and work the handpump until resistance is felt and the green lights come on. At least 120 strokes will be required. If the red lights do not come on after the first 12 strokes of the handpump the following procedure should be followed.
- (ii) Check that air bottle pressure is at least 200 lb./sq. in.
NOTE.—If the air pressure is less than 200 lb. sq.in. the aircraft should be landed with undercarriage up.
- (iii) Select undercarriage DOWN and then press the emergency release pedals. It is not necessary to press both pedals at the same time, but a firm push must be applied to move them 3 to 4 inches forward. The corresponding red light should then come on.

NOTE.—It is important when using the pedals to fly straight and level. Applying "g" will merely make it harder to release the pedals.

After using the pedals allow a few seconds for the wheels to drop and then hold open the pneumatic assister valve. Yaw the aircraft once each way *whilst holding the valve open*. The green lights may *not* come on until after the valve has been released.

If they still do not come on after release, the aircraft should be yawed and the assister used, as before, several times.

- (iv) The tailwheel lowers automatically on failure of the hydraulic system and locks on touching down.

PART IV—EMERGENCIES

- (v) If the hydraulic system appears to function correctly when undercarriage DOWN has been selected but the green lights do not show, the pneumatic assister valve should be opened and released. This should bring on the green lights. If the lights have failed, check the visual wing indicators: these should project above the wing and remain steady when yawing the aircraft from side to side if the undercarriage is locked down safely.

61. Hood jettisoning

The hood may be jettisoned by pulling the red handle on the instrument panel. The starboard side panel will be jettisoned with the hood. A pull of about 15 lb. is required to operate the handle.

62. Ditching

- (i) Every endeavour should be made to bale out rather than ditch.
- (ii) If flying low over the sea the aircraft should be pulled up to gain as much height as possible.
- (iii) On the climb undo helmet and disconnect R/T plug. Jettison hood. Do not release harness until baling out has been decided upon.
- (iv) Bale out if sufficient height can be gained.
- (v) If ditching is unavoidable, flaps should be lowered half way and the touchdown made at as low a speed as possible with the tail well down. Drop tanks should be jettisoned.

63. Forced landing

In the event of having to make a forced landing, the glide may be lengthened considerably by moving the propeller speed control fully back if oil pressure is available. With flaps and undercarriage UP, the angle of glide is very flat at about 170 m.p.h. I.A.S.

PART IV—EMERGENCIES

64. Tyre bursting

If a tyre has burst no attempt should be made to land with the undercarriage lowered. Greater safety to the pilot and less damage to the aircraft will result from a belly landing.

65. Emergency equipment

- (i) A crowbar is fitted to the outboard side of the right-hand heelboard.
- (ii) The first-aid outfit is stowed on the inboard face of the radio access panel on the port side of the fuselage.

PART V

ILLUSTRATIONS

	<i>Fig.</i>
Instrument panel	1
Cockpit—port side	2
Cockpit—starboard side	3

KEY TO *Fig. 1*

INSTRUMENT PANEL

1. Undercarriage indicator switch
2. Ignition switches
3. Watch holder
4. Undercarriage warning light
5. Oxygen regulator
6. Undercarriage indicator
7. Starter and booster-coil switches
8. Contactor switch
9. Remote contactor
10. Flap position indicator
11. Dimmer switch (port cockpit light)
12. Dimmer switch (gun sight)
13. Spare bulbs
14. Dimmer switch (starboard cockpit light)
15. Dimmer switch (compass light)
16. Engine speed indicator
17. Boost gauge
18. Fuel tank contents gauge
19. Main tank fuel contents gauge.
20. Compass card holder
21. Oil temperature gauge
22. Oil pressure gauge
23. Coolant temperature gauge
24. Fuel pressure warning light
25. Power failure warning light
26. Pneumatic pressure gauge.

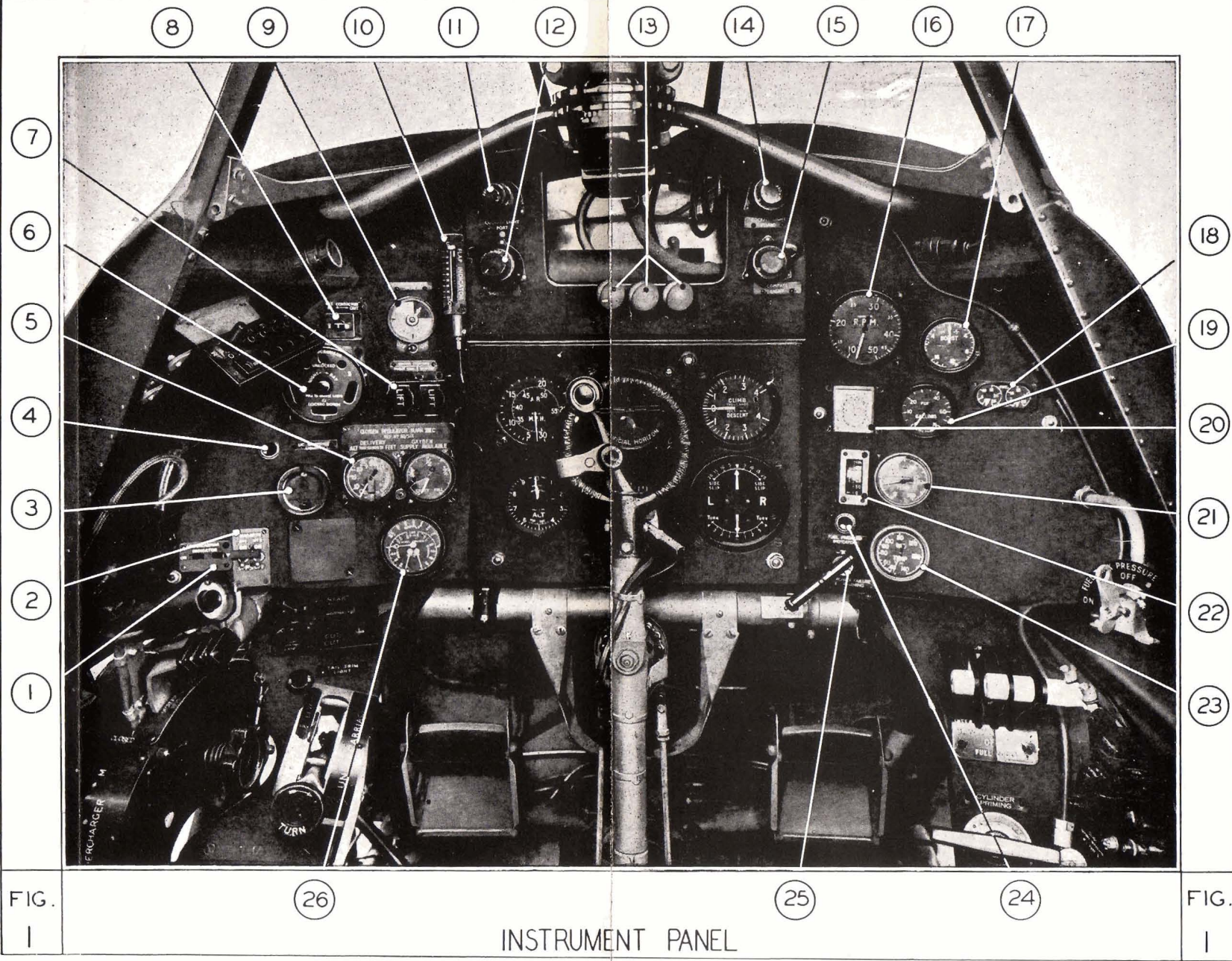
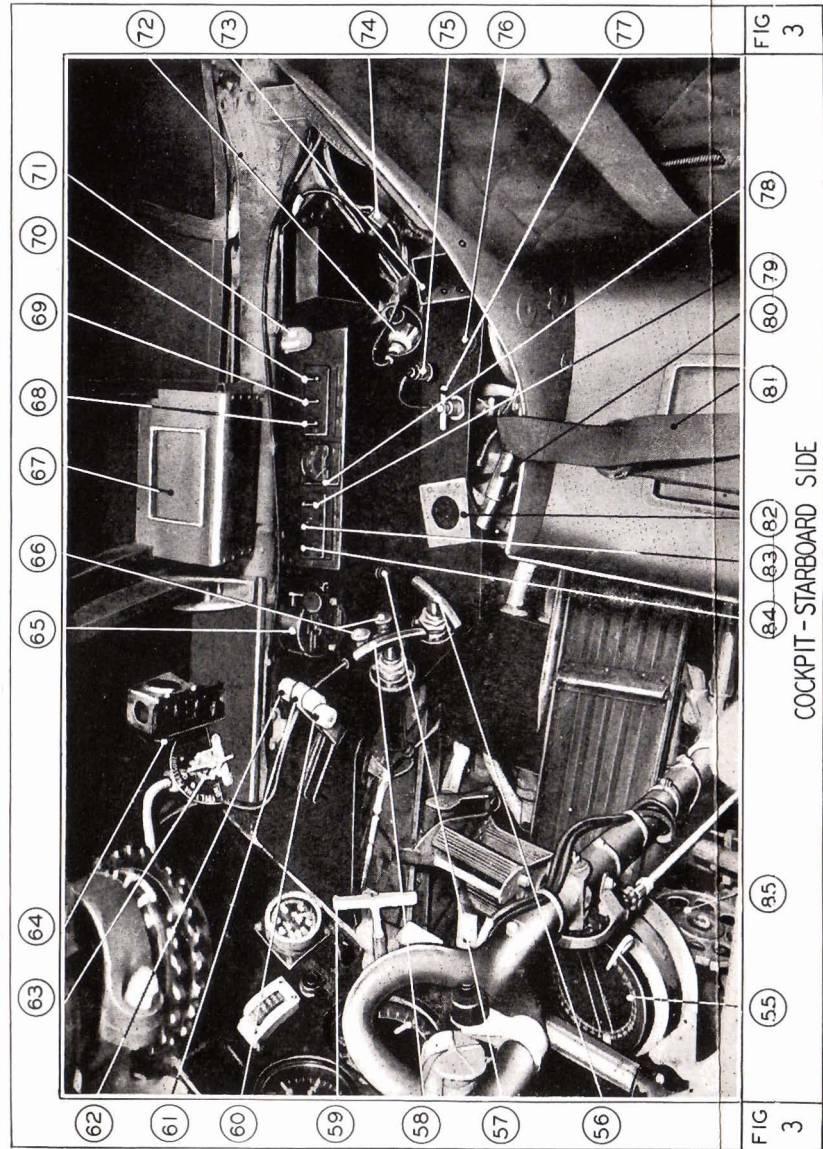
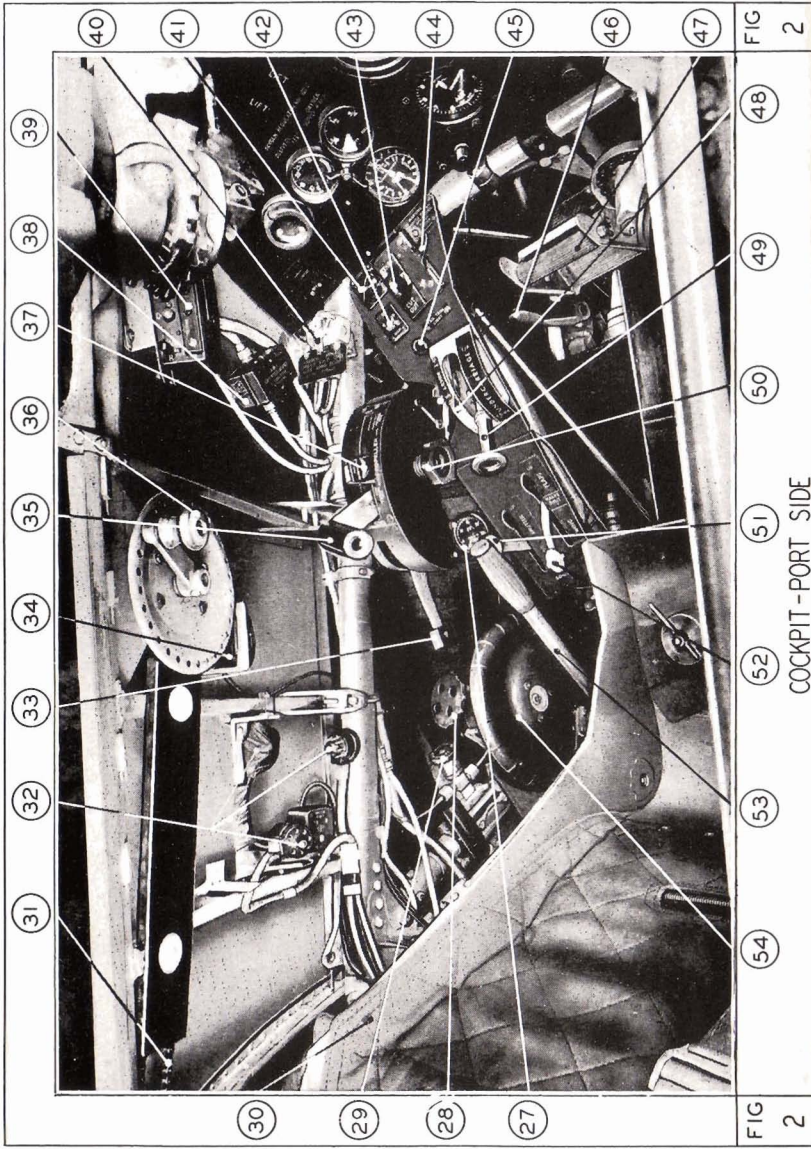

FIG. I

FIG. I

INSTRUMENT PANEL



KEY TO *Figs. 2 and 3*

- | | |
|--|--|
| 27. Hydraulic system pressure gauge (test) | 57. Dimmer switch (electrical panel light) |
| 28. Rudder trimmer | 58. Cylinder priming pump |
| 29. Oxygen control valve | 59. Hood jettison handle |
| 30. Pilot's seat | 60. Fuel cock lever—Interspar tanks |
| 31. Sliding hood mechanism | 61. Fuel cock lever—Main tank |
| 32. Provision for I.F.F. | 62. Fuel cock lever—Nose tank |
| 33. Supercharger lever | 63. Pressurising cock |
| 34. Demolition switches | 64. Cockpit heat control |
| 35. Throttle lever | 65. Signalling switchbox |
| 36. Hood operating handle | 66. Windscreen de-icer pump |
| 37. Propeller control lever | 67. Engine data card holder |
| 38. Ignition test switches | 68. Navigation lights switch |
| 39. T.R.1143 control unit | 69. Resin lamps switch |
| 40. Undercarriage assister control | 70. Camera master switch |
| 41. Landing lamp switch | 71. Electrical panel light |
| 42. Beam approach switch | 72. Heated clothing socket |
| 43. Cut-out lever | 73. Map case |
| 44. Cut-out safety catch | 74. Mic.-tel. socket |
| 45. Dimmer switch (trimmer light) | 75. Dummy socket (footage indicator plug) |
| 46. Undercarriage up-lock release pedal | 76. Oil dilution button |
| 47. Rudder pedal | 77. Cartridge starter re-loading handle |
| 48. Undercarriage lever safety catch | 78. Voltmeter |
| 49. Undercarriage lever | 79. Heated-clothing switch |
| 50. Throttle friction adjuster | 80. Seat adjusting lever |
| 51. Radiator shutter lever | 81. Pilot's harness |
| 52. Flap lever | 82. Footage indicator wedge plate |
| 53. Hydraulic handpump | 83. T.R.1143 master switch |
| 54. Elevator trimmer | 84. Pressure-head heater switch |
| 55. Compass | 85. Rudder bar handwheel |
| 56. Carburettor priming pump | |